

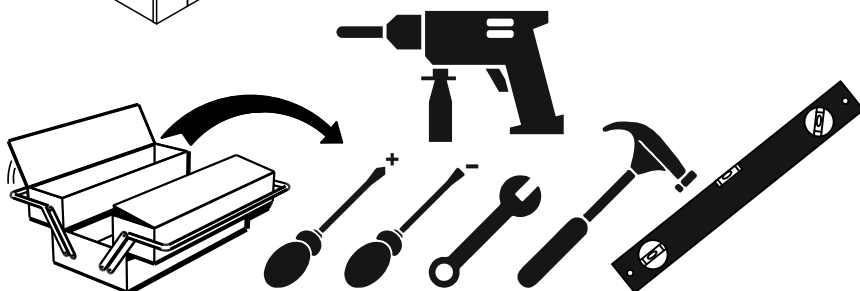

MULTIMO

250- NOVA QUEEN BED

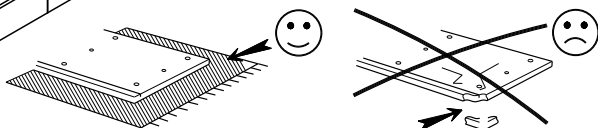

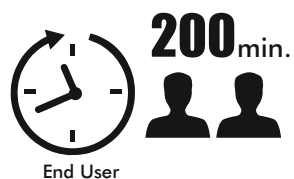
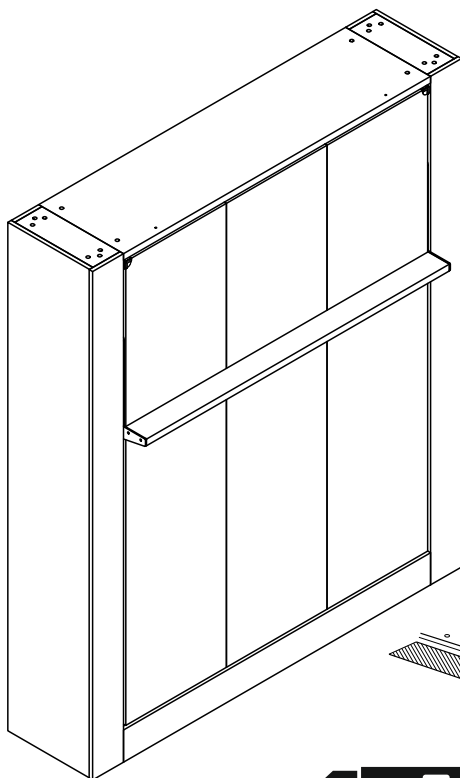

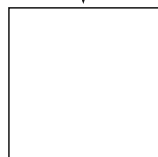





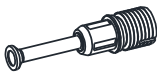

VIDEO

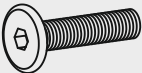
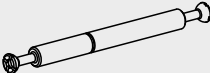

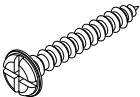

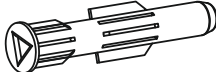

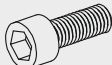
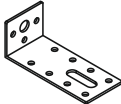



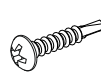
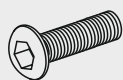
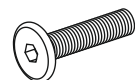

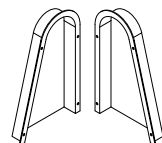
link

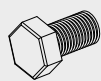
Track Title	Piece	(inch)			(mm)			
		Thickness	Length	Width	Piece	Thick	Height	Most
A-R / A-L	2	0,71	89,76	16,61	2	18	2280	422
B	1	0,71	62,60	16,61	1	18	1590	422
C	1	1,18	62,60	17,32	1	30	1590	440
D-R / D-L	2	0,71	89,76	5,55	2	18	2280	141
E-R / E-L	2	0,71	89,76	6,30	2	18	2280	160
F	2	0,71	15,91	5,55	2	18	404	141
G	2	1,18	15,91	5,55	2	30	404	141
H-R / H-L	2	0,71	15,91	36,30	2	18	404	922
K	1	0,71	62,60	7,09	1	18	1590	180
L	1	0,71	62,60	11,61	1	18	1590	295
M	6	0,71	15,91	5,51	6	18	404	140
N	1	1,18	61,73	4,33	1	30	1568	110
P	1	0,71	62,60	5,67	1	18	1590	144
R-1	2	0,71	81,89	20,51	2	18	2080	521
R-2	1	0,71	81,89	20,51	1	18	2080	521
S (OPTIONAL HEADBOARD)	0	1,97	62,40	34,45	0	50	1585	875

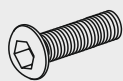
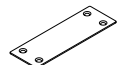
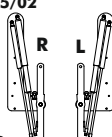
Accessories List

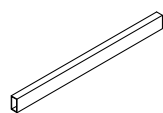
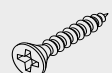
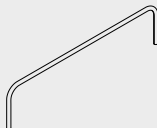
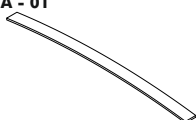
MXN 02  60 / piece	MNG - 01  104 / piece	OT-054  2 / piece	CT - 01 (6x40) mm  2 / piece
MXN - 03  22 / piece	KVL 01  112 / piece	VDA - 01 (6,5x50) mm  4 / piece	VD - 02 (3,5x25) mm  2 / piece
PL - 02 (8x22x1) mm  3 / piece	TFC - 01(8x70) mm  3 / piece	DD - 01 (R10)  3 / piece	VTB - 01 (4,8x16) mm  12 / piece
IM - 02 (6x20) mm  4 / piece	DSE - 01 (40x90x32) mm  3 / piece	TAP - 01  104 / piece	TAP - 02  4 / piece

<p>SG - 01</p>  <p>2 / piece</p>	<p>YSB - 01 (3,9x16) mm</p>  <p>2 / piece</p>	<p>CTM - 02 (8x35) mm</p>  <p>2 / piece</p>	<p>CT - 04 (6x20) mm</p>  <p>2 / piece</p>
<p>OT-056D</p>  <p>2 / piece</p>	<p>OT-056PE</p>  <p>2 / piece</p>	<p>KMT-01</p>  <p>1 / piece</p>	<p>VTB - 02 (4,2x16) mm</p>  <p>80 / piece</p>
<p>CTA - 01 (8x15) mm</p>  <p>12 / piece</p>	<p>PL - 05 (8x16x2) mm</p>  <p>14 / piece</p>	<p>CTM - 05 (8x45) mm</p>  <p>2 / piece</p>	<p>BRK - 01</p>  <p>10 / piece</p>
<p>MKZ - 05/02</p>  <p>1 / piece</p>	<p>SC - 92</p>  <p>2 / piece</p>	<p>PRF</p>  <p>1 / piece</p>	<p>VD - 03 (3,5x18) mm</p>  <p>40 / piece</p>
<p>KOR</p>  <p>1 / piece</p>	<p>LTA - 01</p>  <p>26 / piece</p>		
<p>KKS - 01</p>  <p>2 / piece</p>			

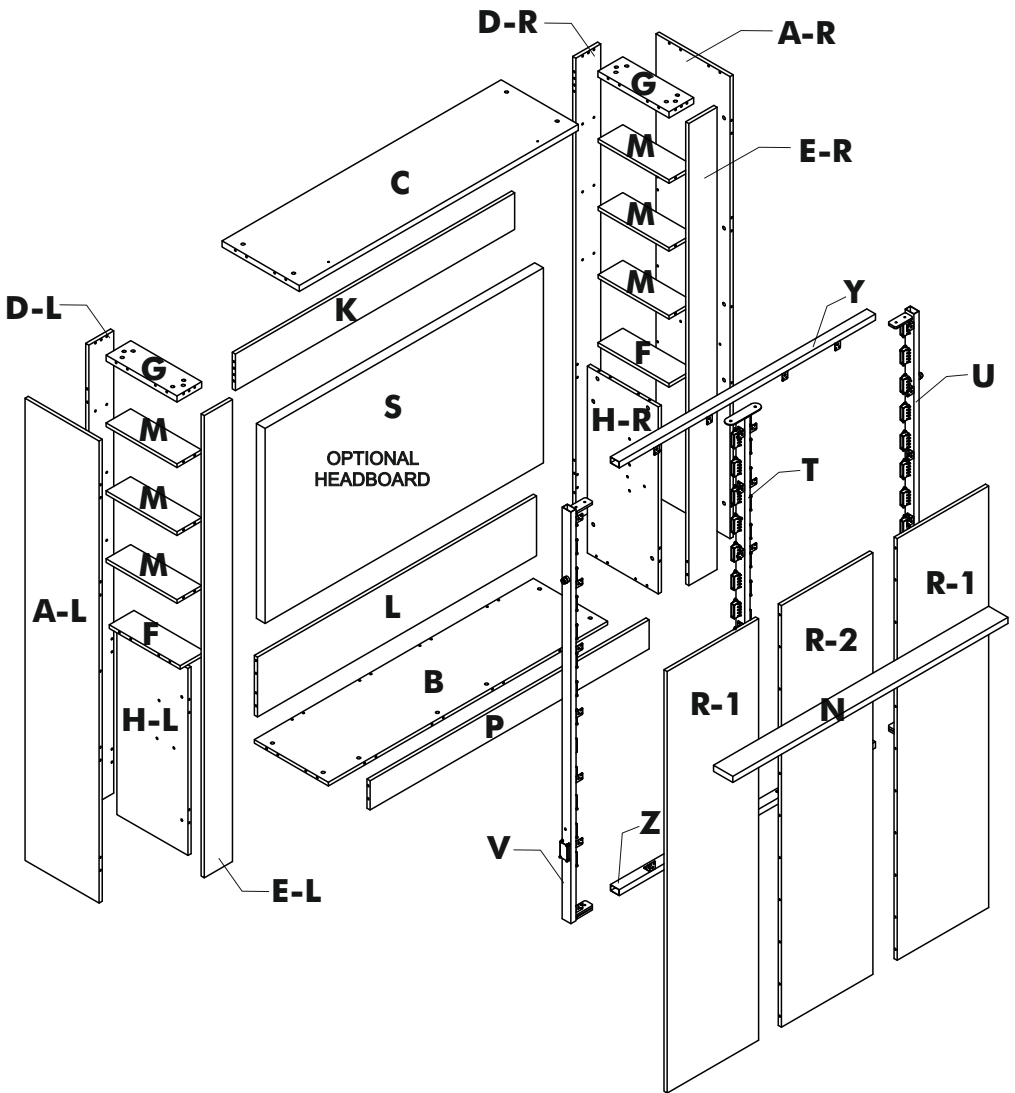

STEP 1

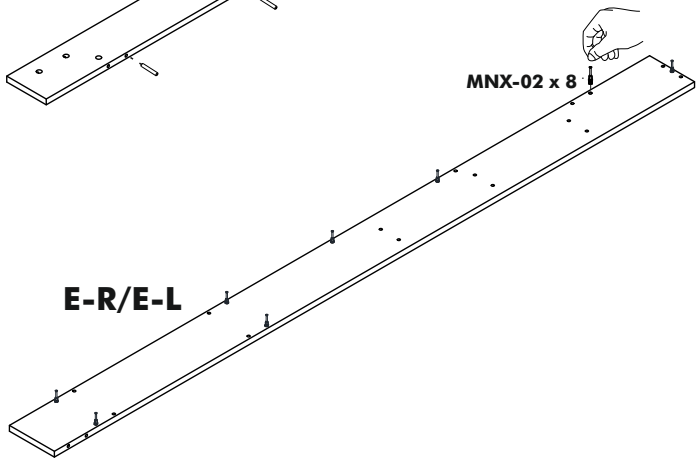
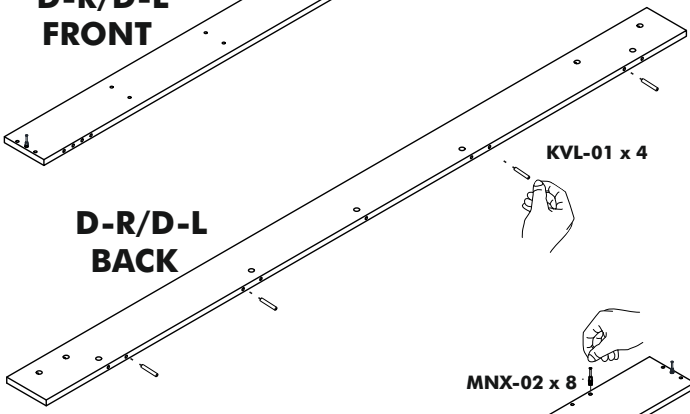
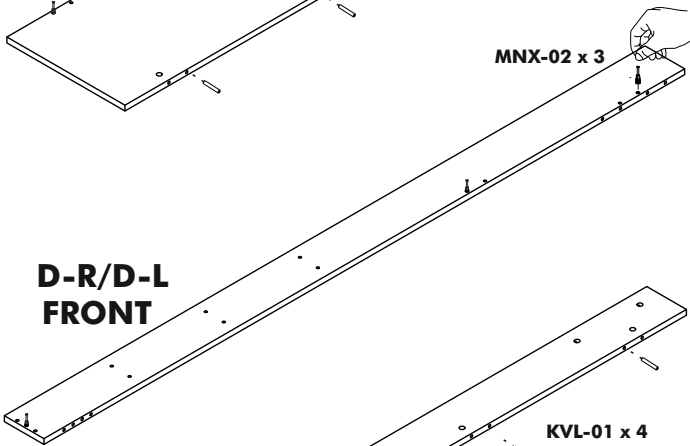
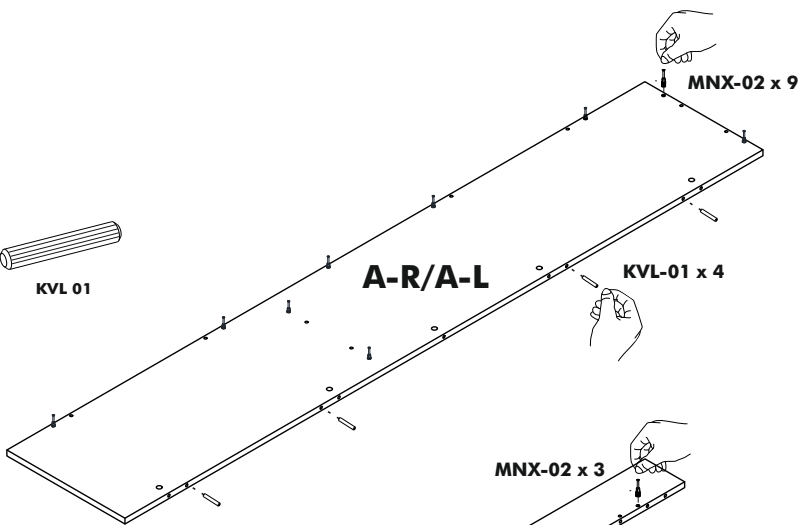
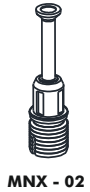

VIDEO

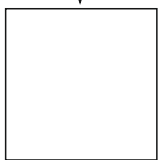

link

STEP 2

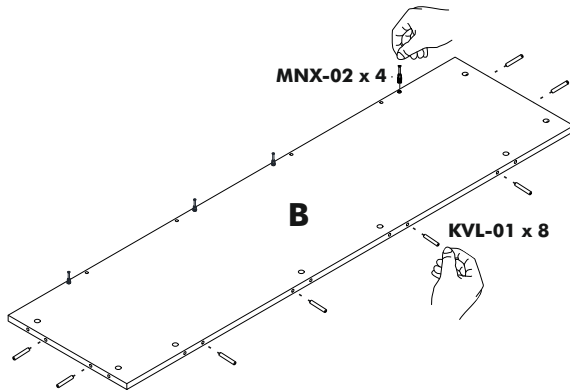
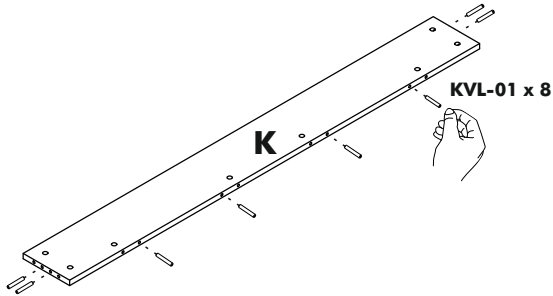
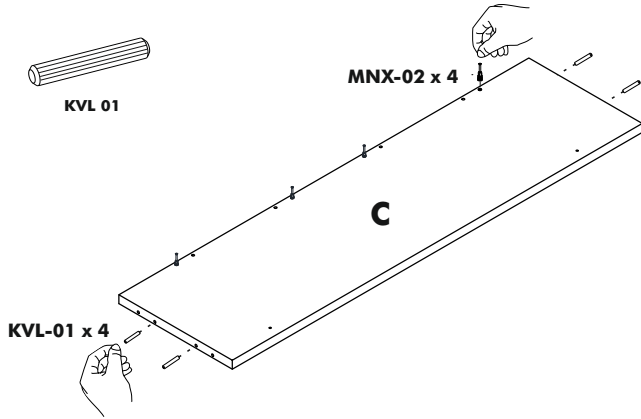
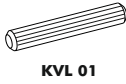

VIDEO

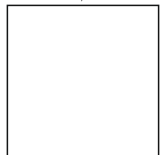

link

STEP 3

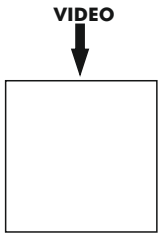
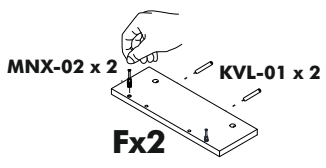
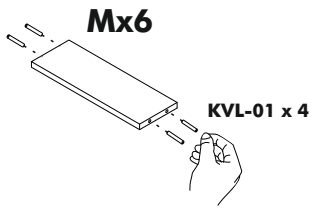
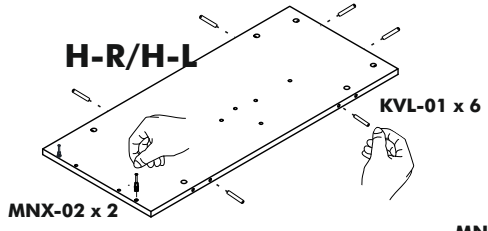
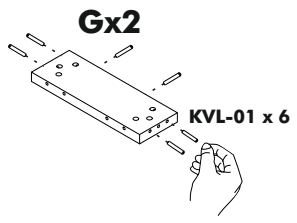
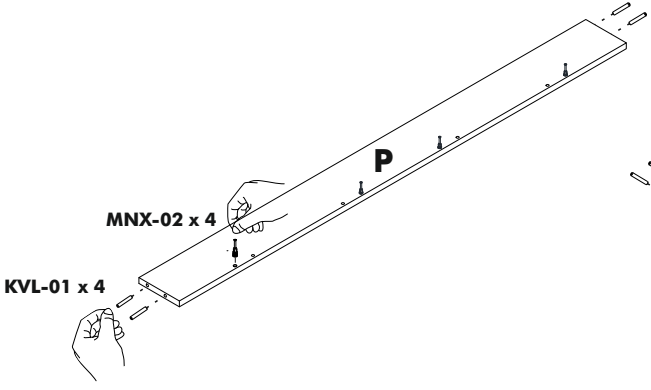
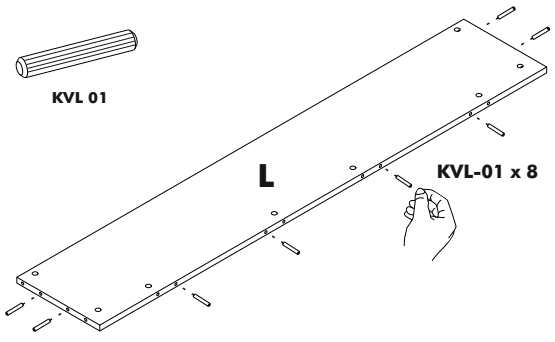
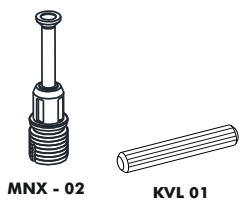

STEP 4

RIGHT / LEFT



MNG - 01

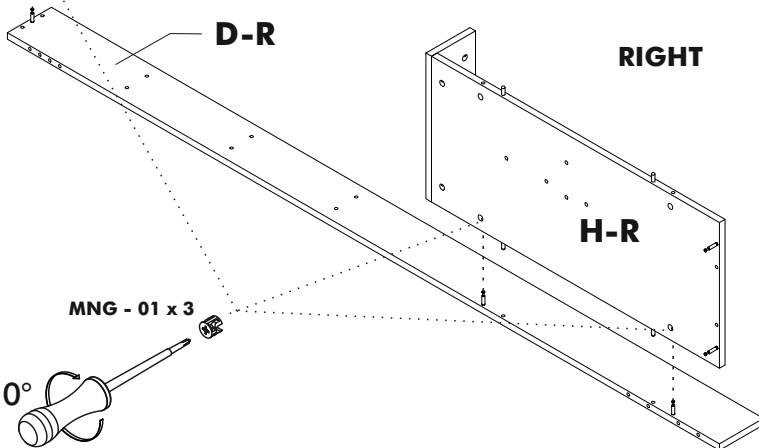
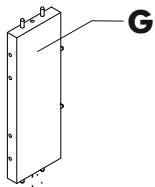
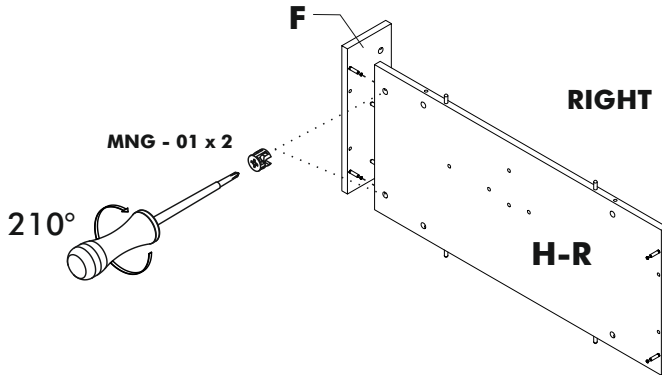

STEP 5



MNG - 01

VIDEO

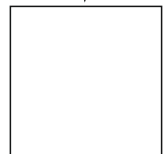

link

STEP 6

RIGHT / LEFT

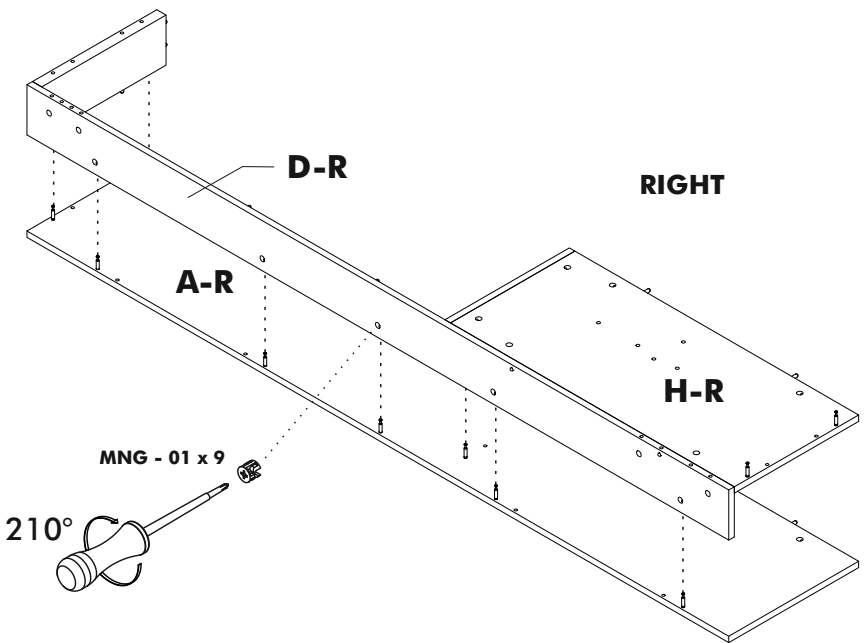

STEP 7

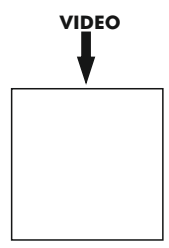
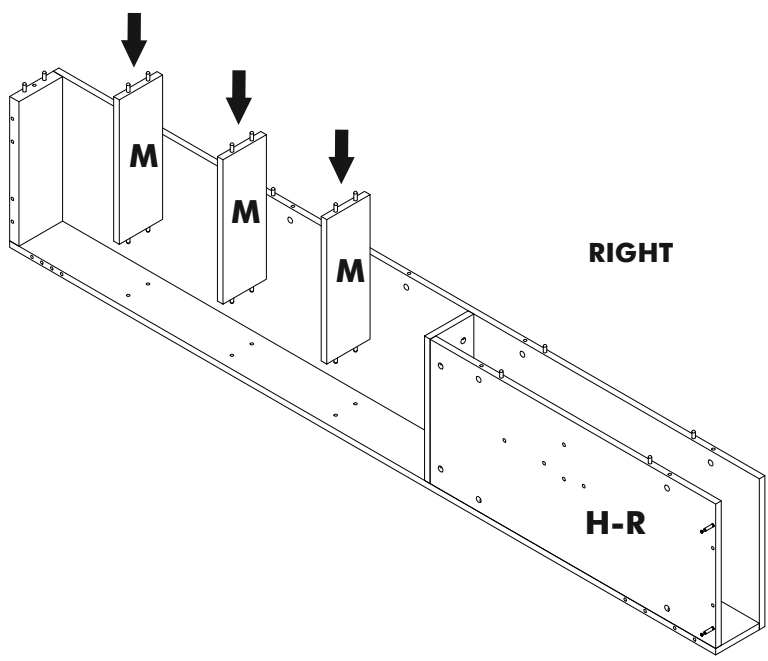

STEP 8



RIGHT / LEFT

RIGHT

E-R

MNG - 01 x 4



Don't forget to add MNG-01 before adjusting part "E"

MNG - 01 x 2

STEP 9



RIGHT

1

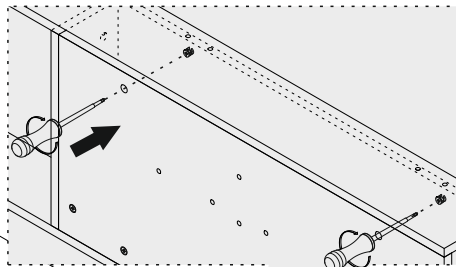

2

MNG - 01 x 2



VIDEO

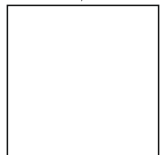

link

STEP 10

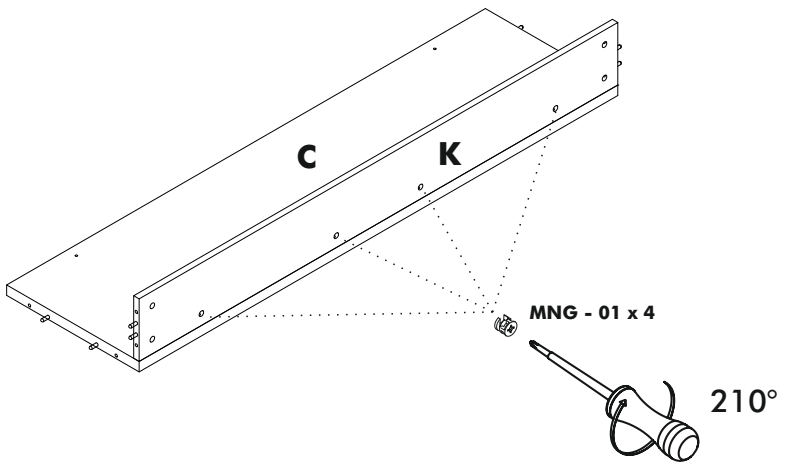

STEP 11

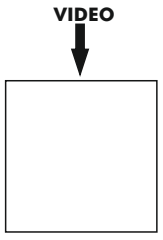
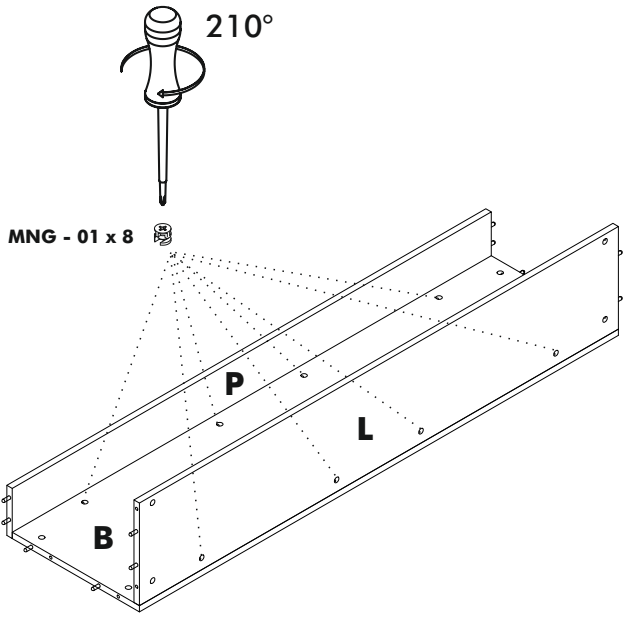

STEP 12

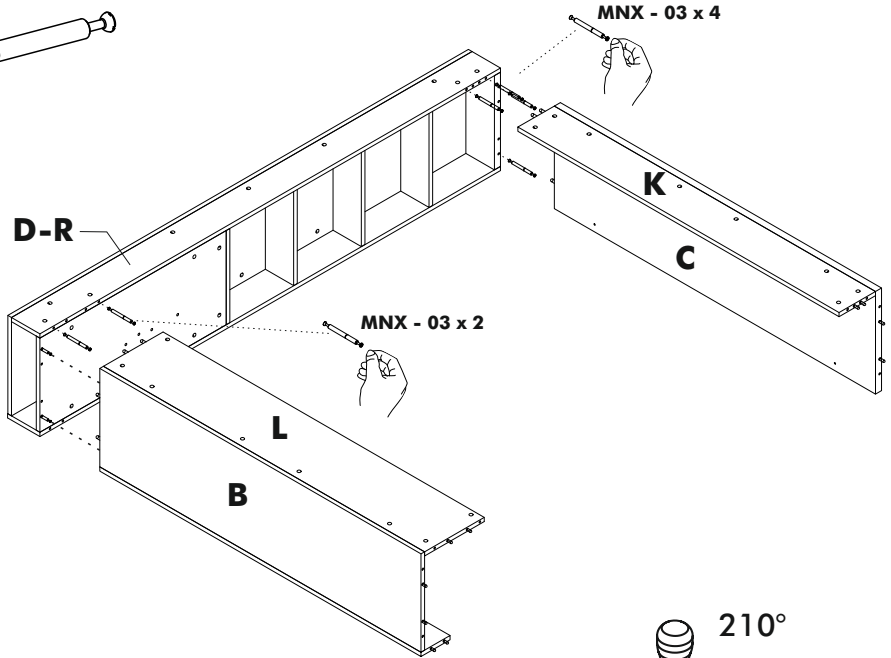
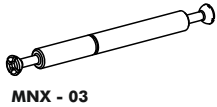

STEP 13

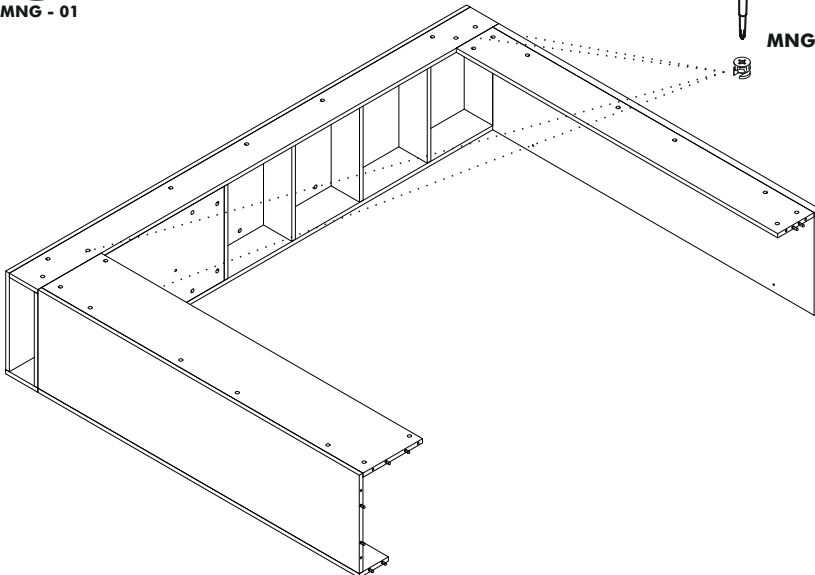
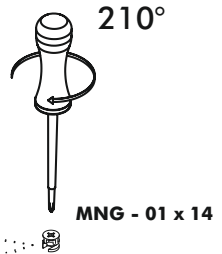

VIDEO

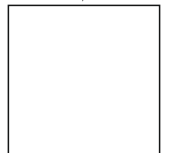

link

STEP 14

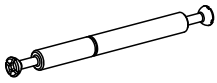

MNX - 03

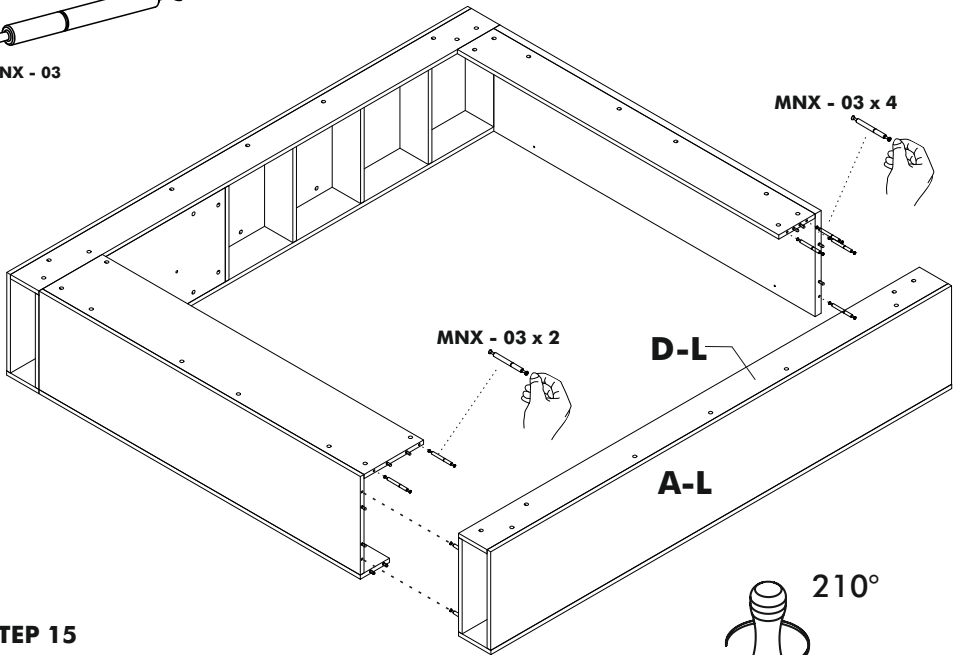

STEP 15



MNG - 01

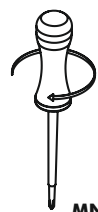
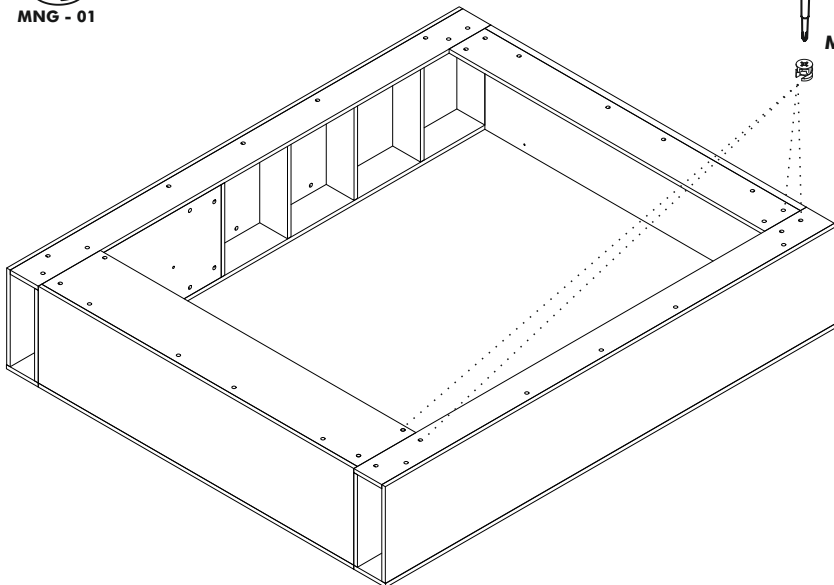

210°

MNG - 01 x 14

VIDEO

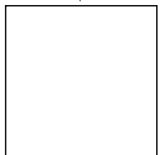

link

OPTIONAL
HEADBOARD

STEP 16

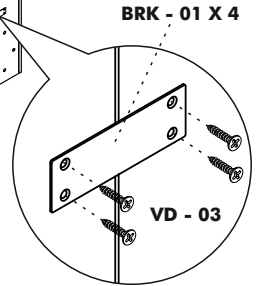
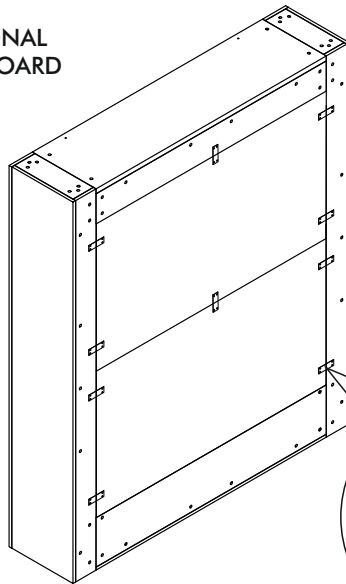
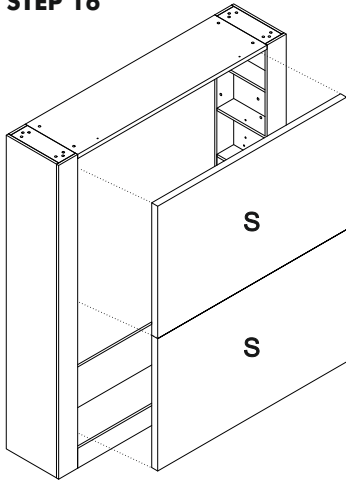

ATTENTION!!!

Must be secured to the wall made of brick, concrete or similarly strong material.
Mounting to wooden or metal studs is also acceptable.

STEP 17

Do not mount directly to sheetrock or paper-mache type walls not supported by studs.

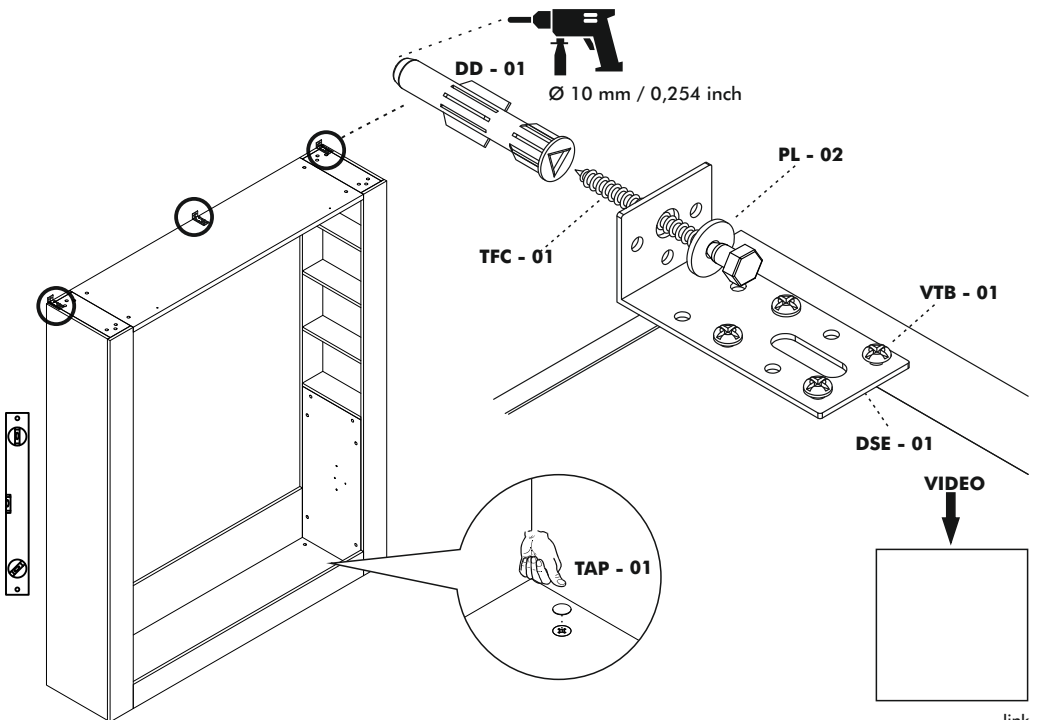

WALLS MADE OF DRYWALL WITH WOODEN OR METAL STUDS

STEP 17-1

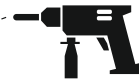
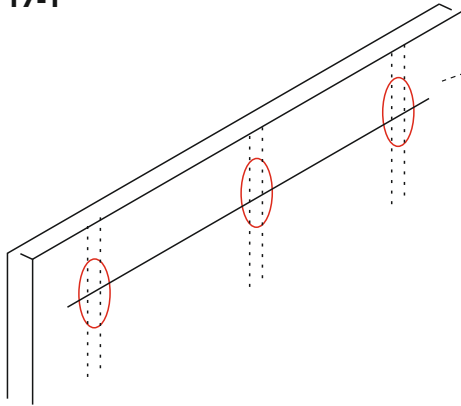

Ø 10 mm / 0,254 inc



FIRST LOCATE THE STUDS BY USING "STUD FINDER" IN THE WALL AND DRILL IT ACCORDING TO THE HEIGHT MEASUREMENTS GIVEN ON THE SIDE. UPPER HOLES SHOULD BE DRILLED FOR ATTACHING BED AT NEXT STEP.

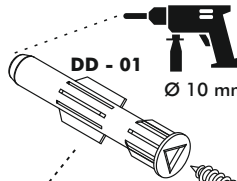

DD - 01

Ø 10 mm / 0,254 inch

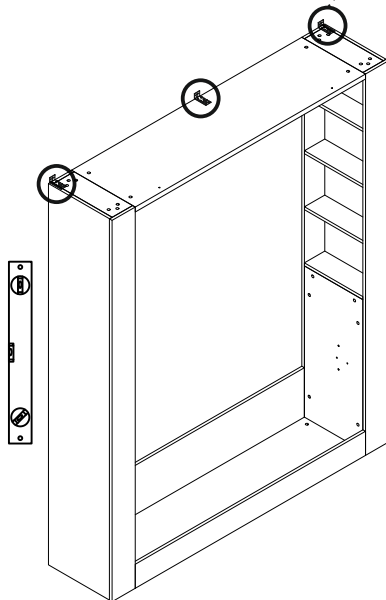

TFC - 01

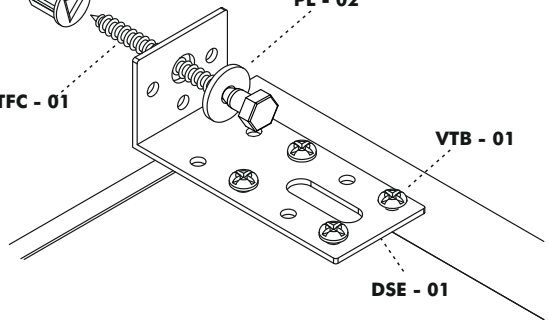

PL - 02

VTB - 01

DSE - 01

NOT INCLUDED

SUPPLY DRYWALL FASTENERS APPROPRIATE TO YOUR WALL TYPE. WE RECOMMEND USING STEEL TOGGLE BOLT ANCHOR THAT SHOWN BELOW



STEP 18

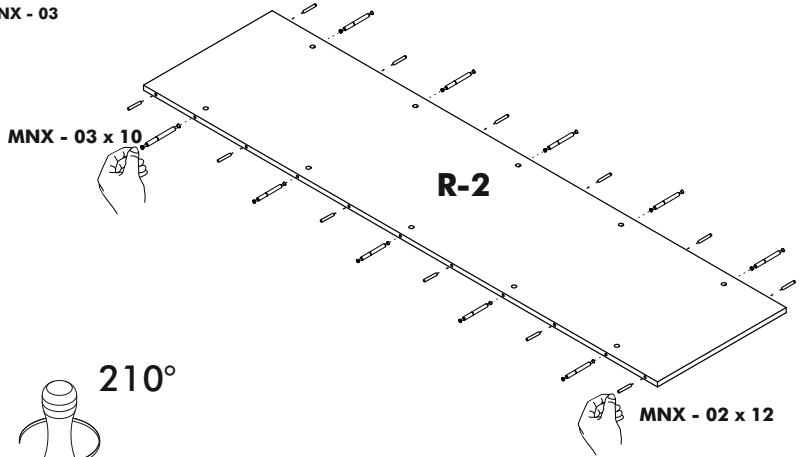
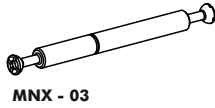
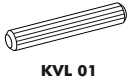

STEP 19

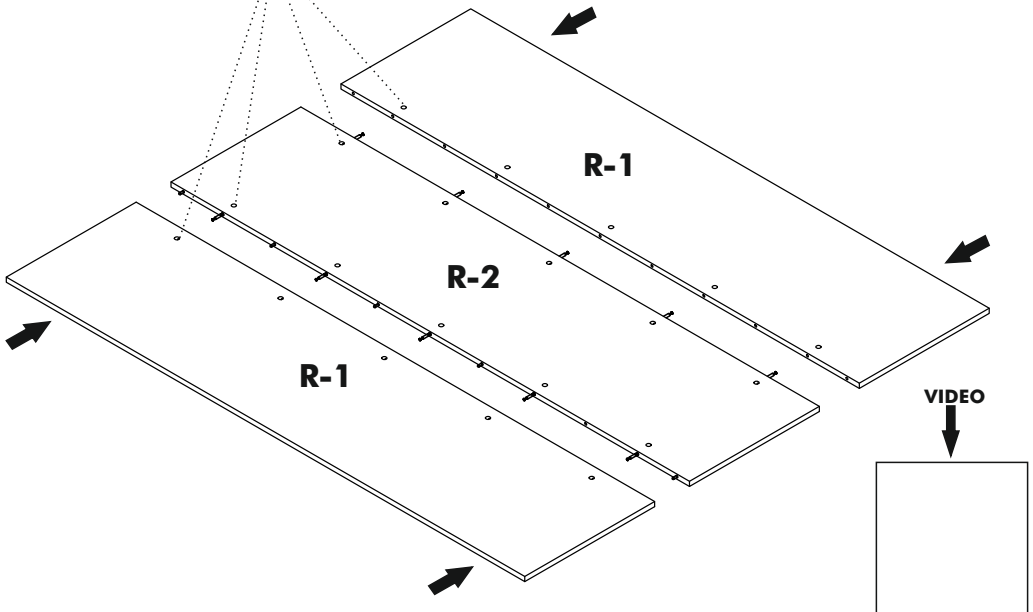
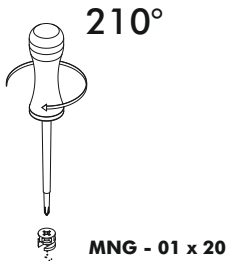

STEP 20

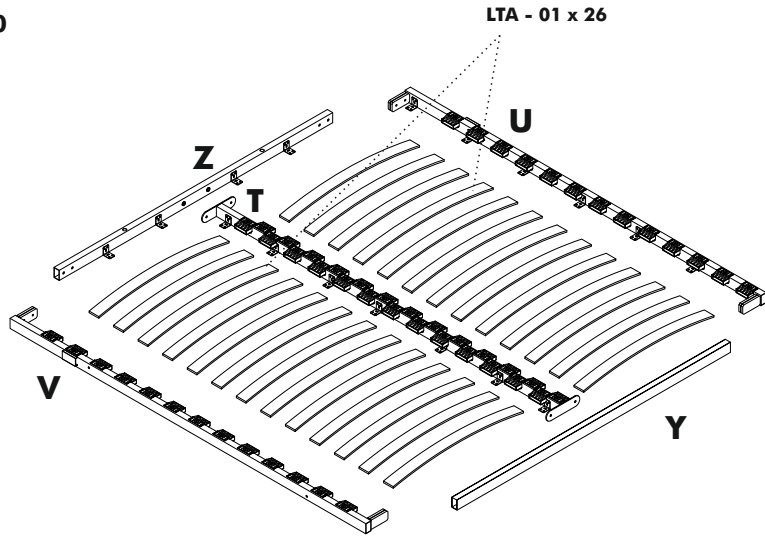

STEP 21

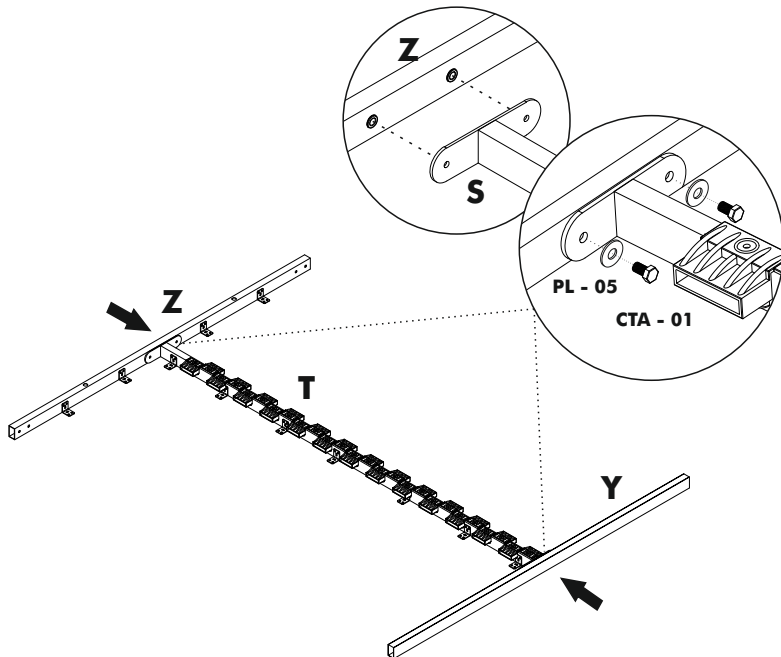

VIDEO

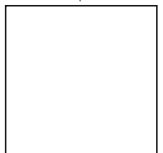

link

STEP 22

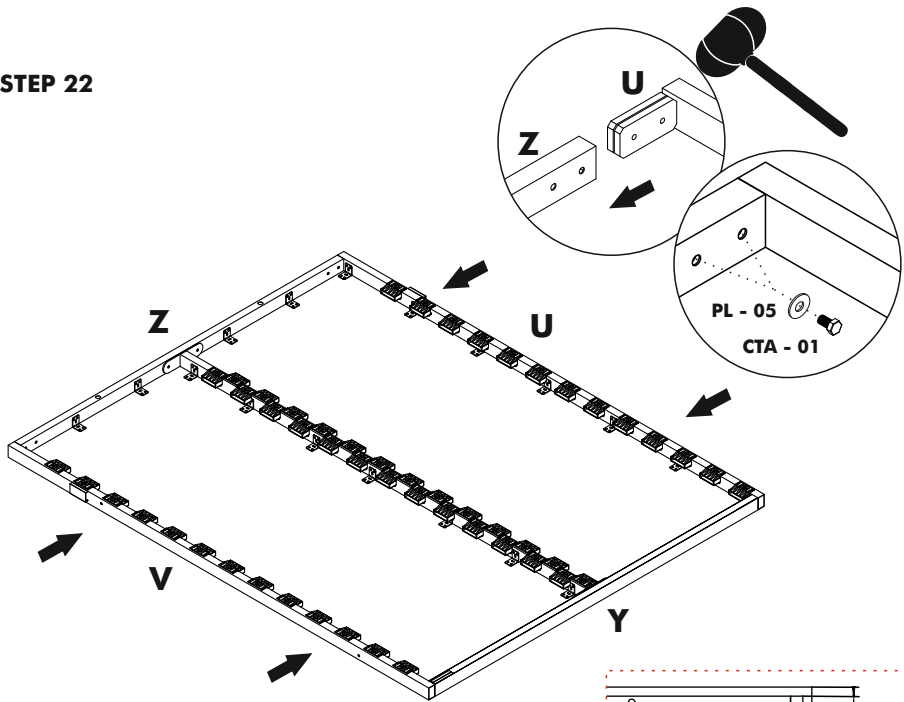

STEP 23

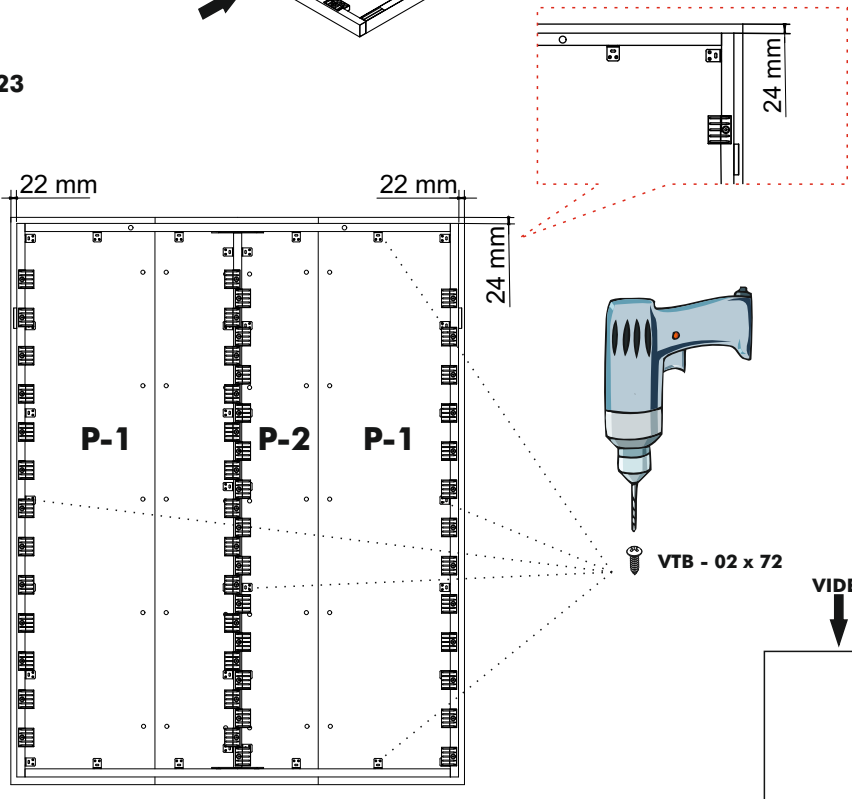

STEP 24

Unscrew the Screws

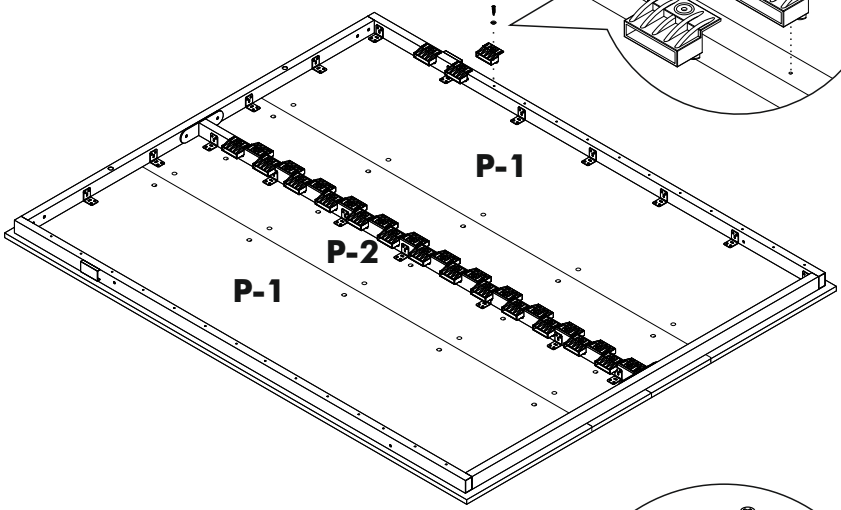

STEP 25

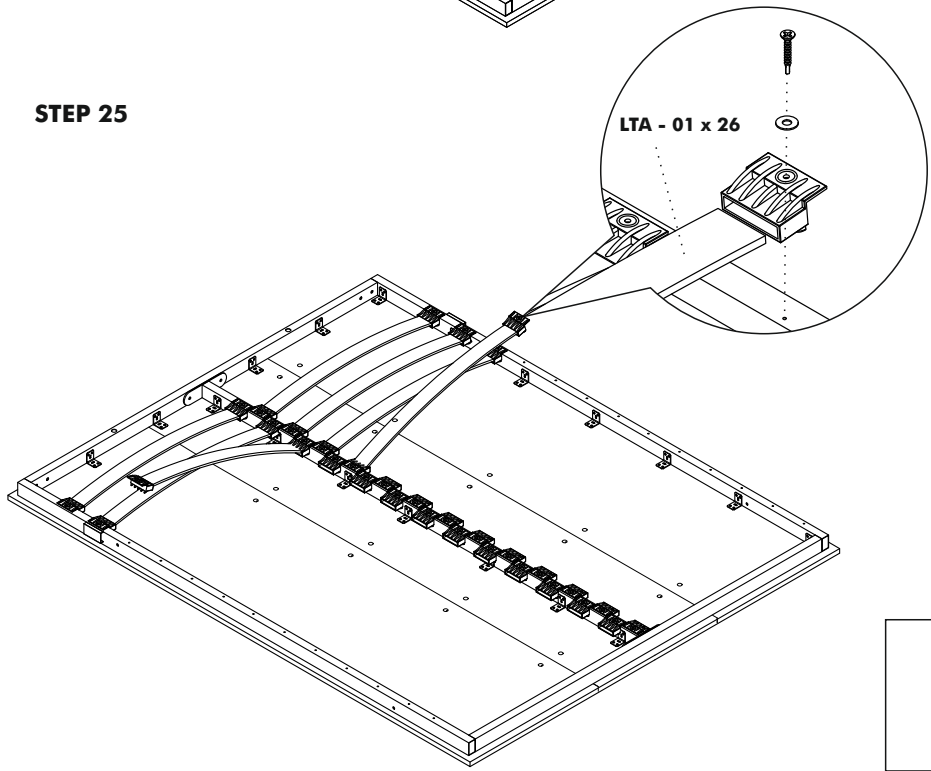

VIDEO

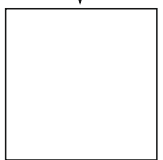

link

STEP 26

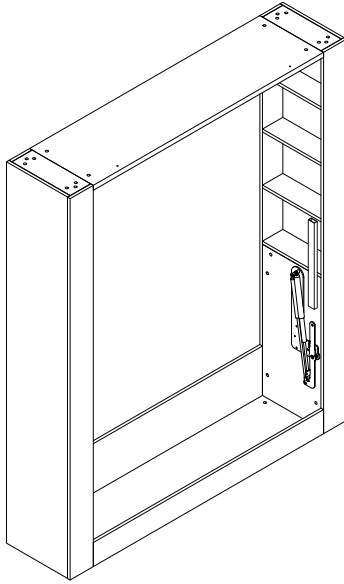

CAUTION
DO NOT UNLOCK BEFORE INSTALL

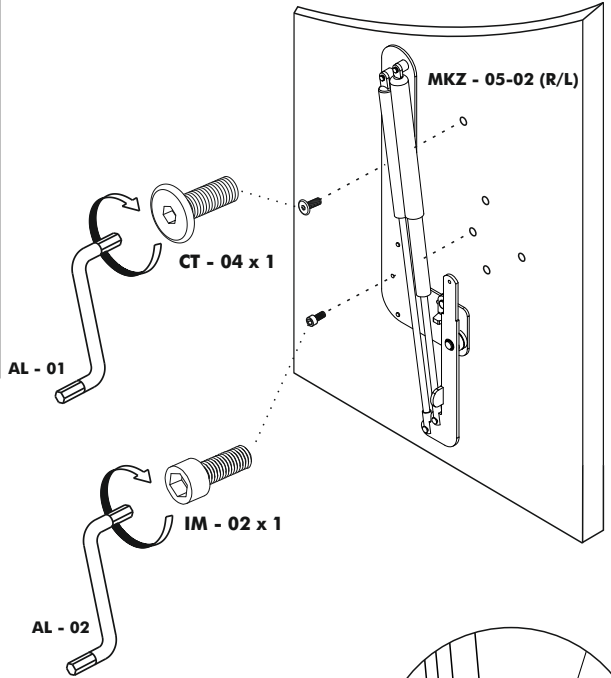

STEP 27

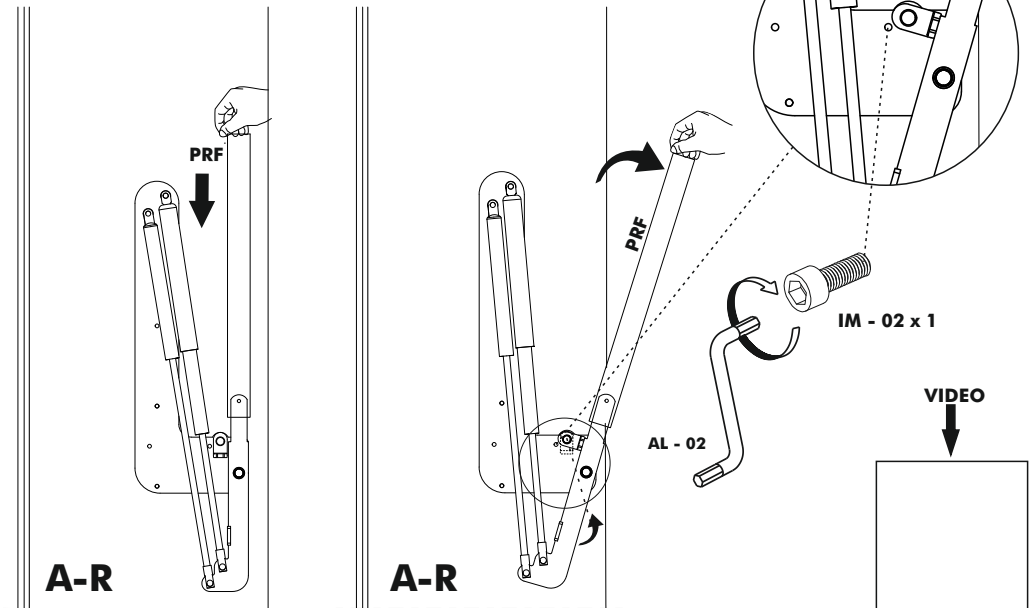

STEP 28

45-50°

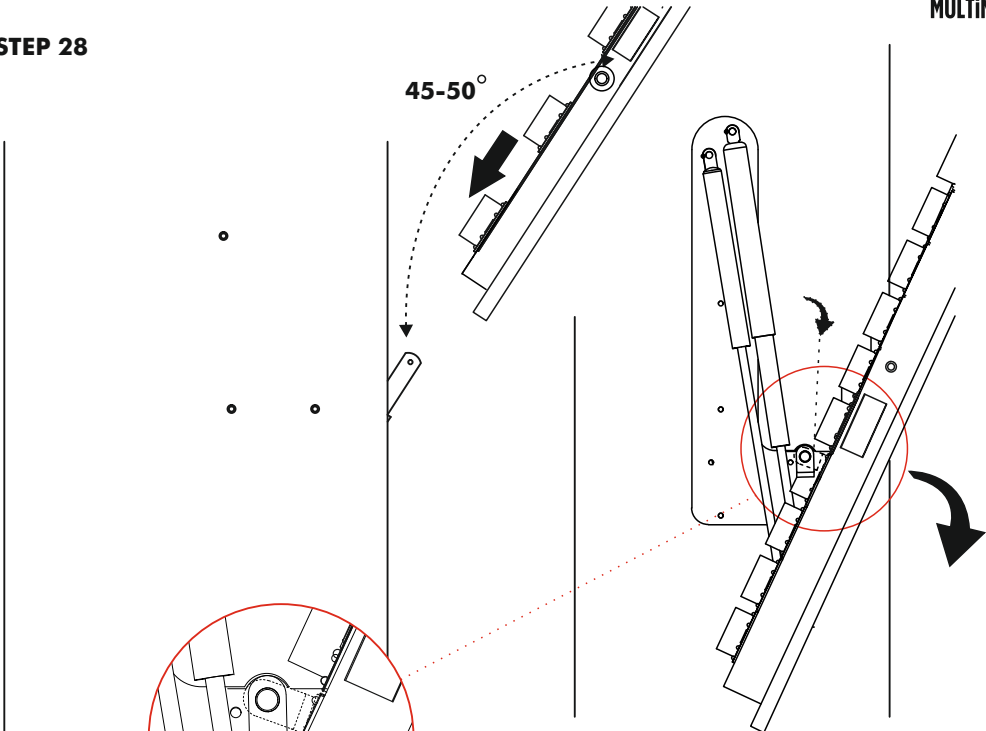

LET THE STOPPER LOCK MOVE DOWN !!!

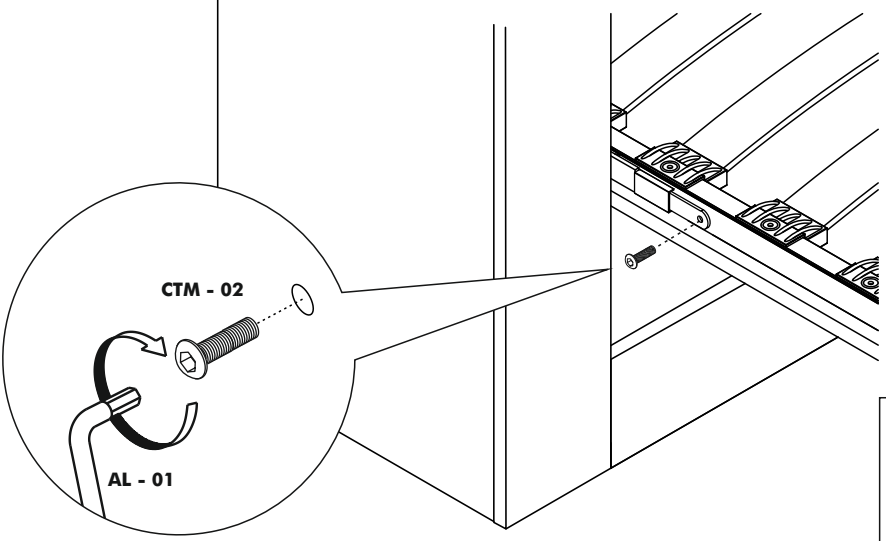
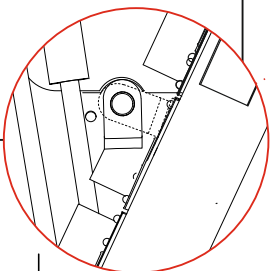

CTM - 02

AL - 01

VIDEO

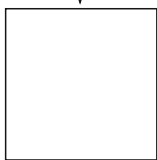

link

STEP 29

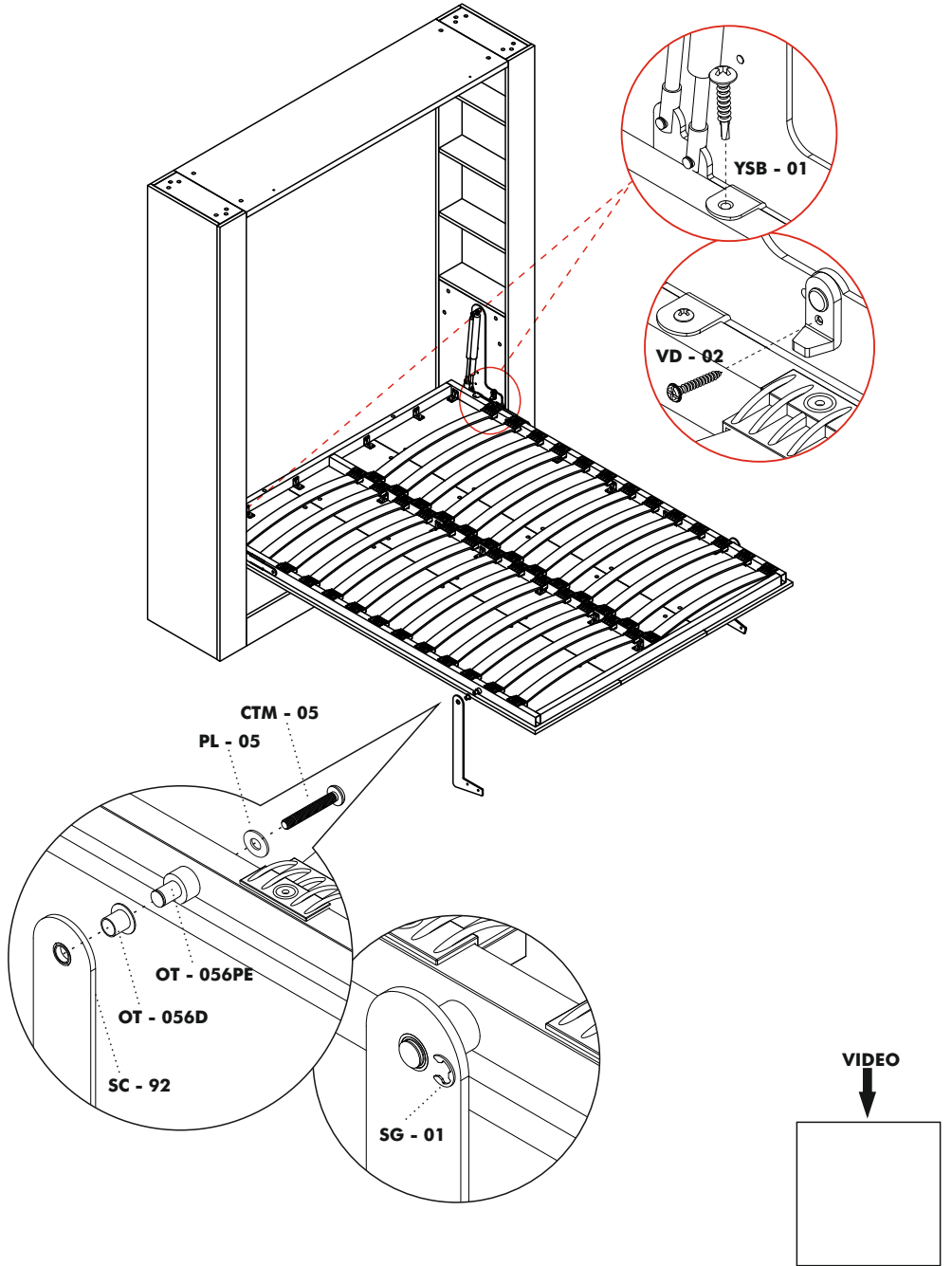

STEP 30

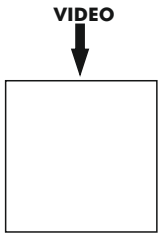
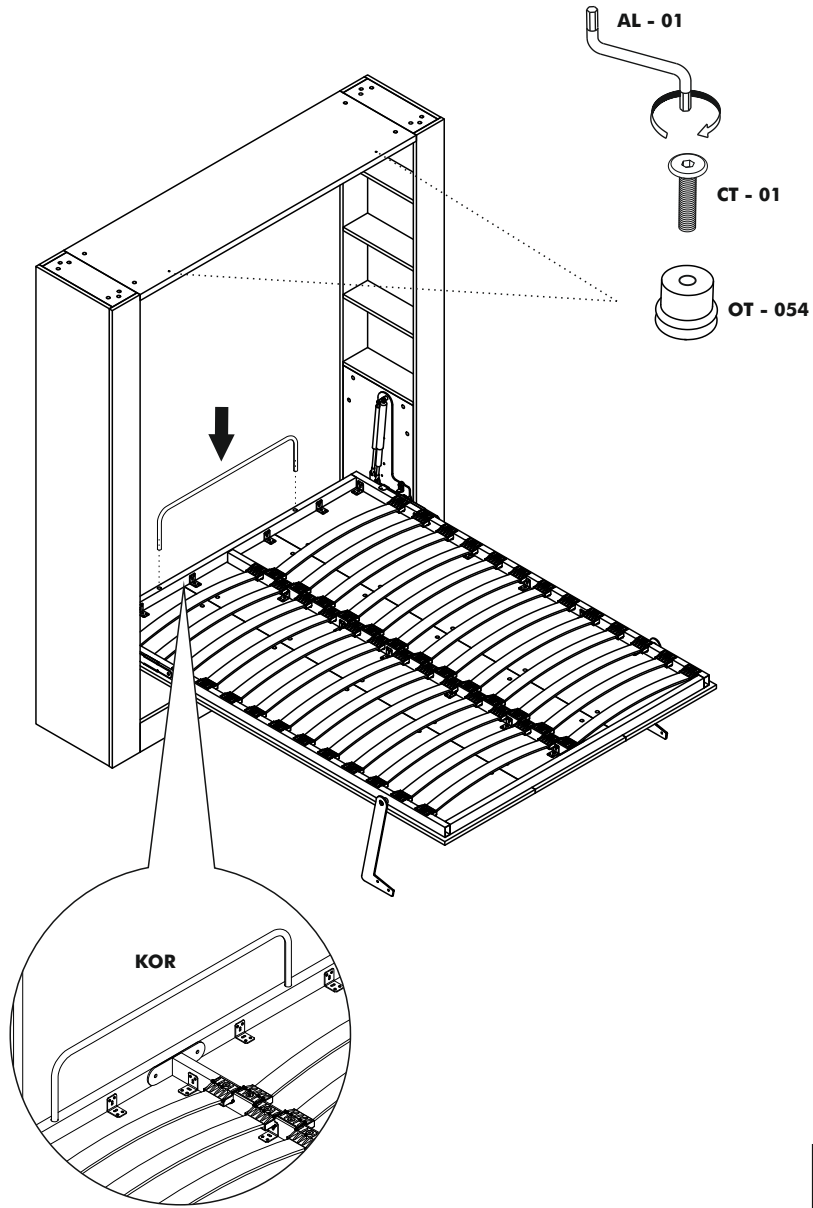

STEP 31

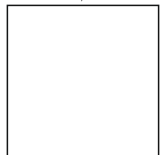
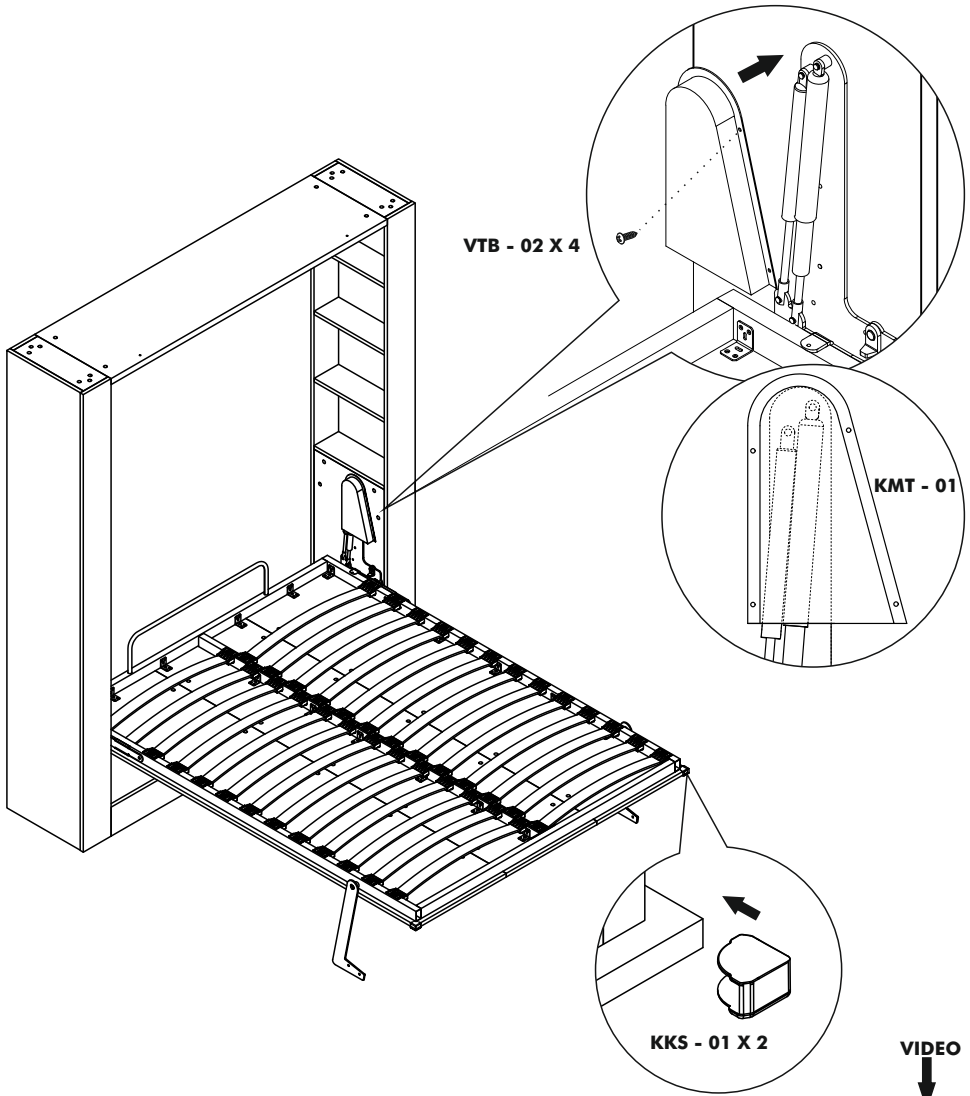

link

STEP 32

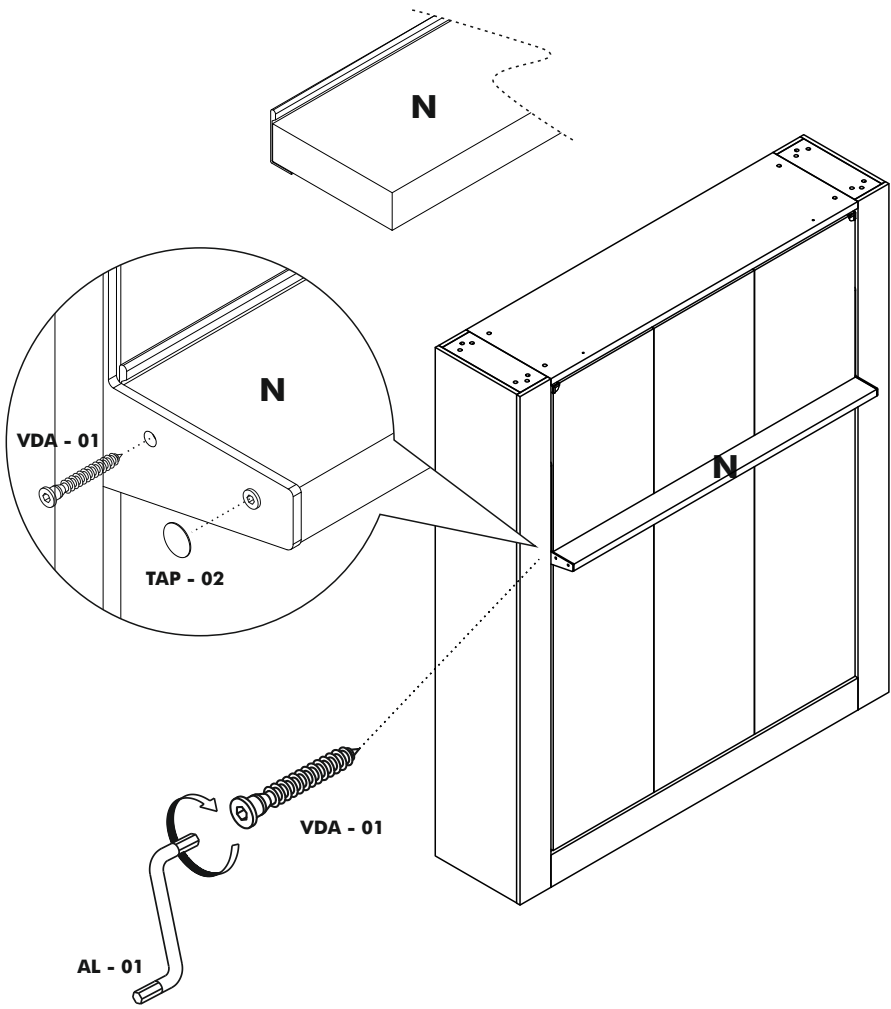

VIDEO

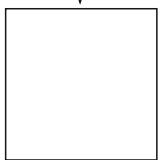

link

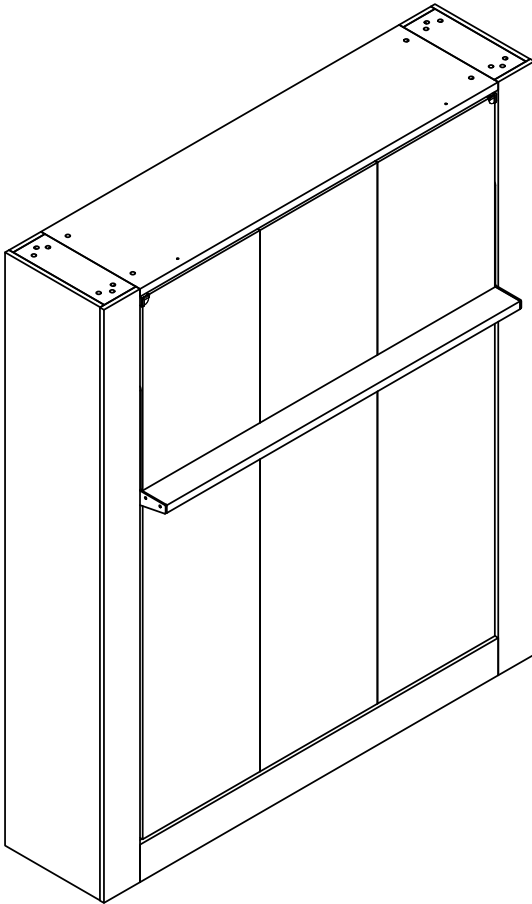

VIDEO

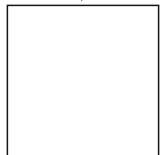

link

ATTENTION / HOW TO / READ ME / OWNER'S GUIDE

1. When mounting on a regular drywall, furniture must be fastened to wood or metal studs. Solid walls made of brick, concrete or similar strong material are also acceptable. Do not mount furniture to paper-mache or sheet rock like material without properly attaching to stud.
2. For safety and product longevity you must periodically inspect the mounting and mechanical connections for integrity and tightness. Confirm hardware remains properly affixed and connections snug.
3. Wall Bed mattress thickness may not exceed 8 inch. Take care to remove pillows and excess blankets before closing. Doing so keeps mechanism free of obstruction and unnecessary stress.
4. Do not lean or rest heavy objects on side or top of furniture. This may cause balance issues and compromise the integrity of your mounting connections.
5. Please use the furniture's beds, desks and shelving as intended. Not designed to be sat, stood, leaned, jumped (etc) on. Improper use may cause personal injury and damage to property.
6. With seasonal humidity change you must inspect interior and exterior of furniture.
7. Single, Twin, Twin XL beds accommodate the weight of one person. Improperly sleeping more than one person risks injury to person and damage to property.
8. Before any un-mounting or disassembly please contact Multimo for technical support and instruction. Failure to properly detach risks injury to person and damage to property.
9. For Bunk Beds:
 - a. Always use provided ladder when accessing top bunk.
 - b. Be slow, careful and aware of surroundings when opening top bunk.
 - c. Do not horseplay. Beds are to be slept on only.
 - d. Some have legs that fully extend when open- be aware of where the leg is and will be.



MULTiMO

www.multimo.com