

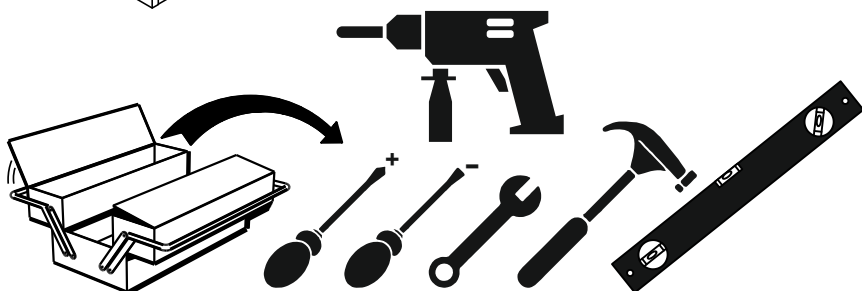

MULTIMO

225-ROYAL PLUS 160

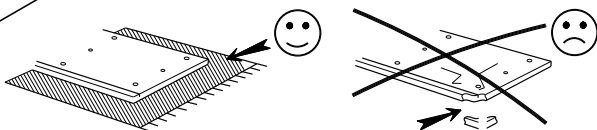
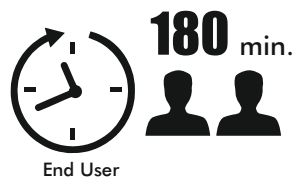
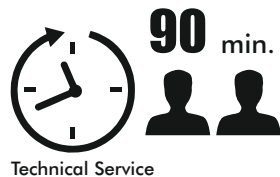
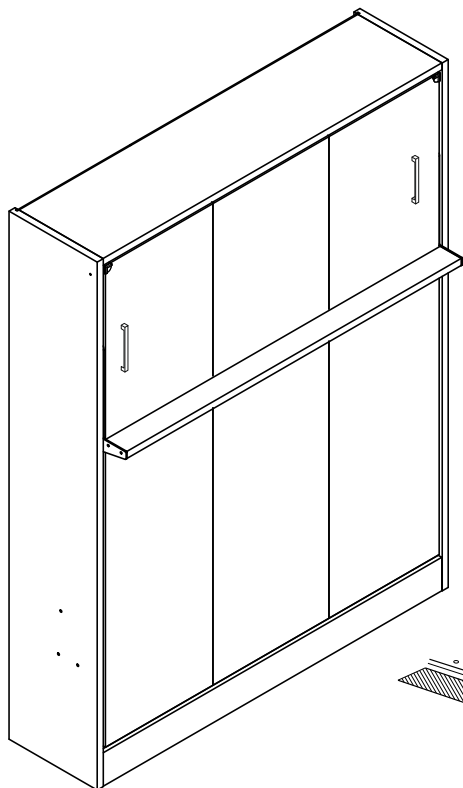

VIDEO

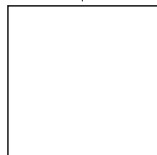









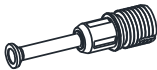

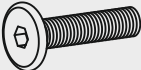
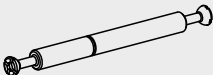
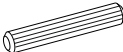

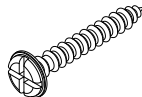

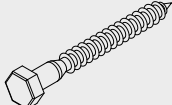
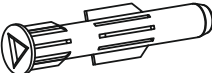

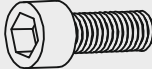
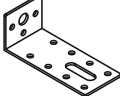
link

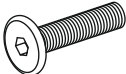
Assembly Instructions

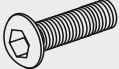
Track Title	Piece	(inch)			(mm)			
		Thickness	Length	Width	Piece	Thick	Height	Most
A-R / A-L	2	1,18	89,76	17,32	2	30	2280	440
B	1	0,71	66,54	16,54	1	18	1690	420
C	1	1,18	66,54	16,50	1	30	1690	419
D	1	0,71	66,54	11,81	1	18	1690	300
E	3	0,31	89,25	22,32	3	8	2267	567
F	1	0,71	66,54	5,67	1	18	1690	144
G-1	2	0,71	81,89	21,85	2	18	2080	555
G-2	1	0,71	81,89	21,85	1	18	2080	555
H	1	1,18	65,67	4,33	1	30	1668	110

Accessories List

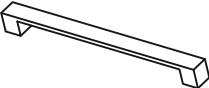
MXN 02  24 / piece	MNG - 01  44 / piece	OT-054  2 / piece	CT - 01 (6x40) mm  2 / piece
MXN - 03  10 / piece	KVL 01  34 / piece	VDA - 01 (6,5x50) mm  4 / piece	VD - 02 (3,5x25) mm  32 / piece
PL - 02 (8x22x1) mm  3 / piece	TFC - 01(8x70) mm  3 / piece	DD - 01 (R10)  3 / piece	VTB - 01 (4,8x16) mm  12 / piece
IM - 01 (6x30) mm  4 / piece	DSE - 01 (40x90x32) mm  3 / piece	TAP - 01  44 / piece	TAP - 02  4 / piece
CT - 02 (6x30) mm  2 / piece	VKP - 01 (22) mm  4 / piece	YSB - 01 (3,9x16) mm  2 / piece	CTM - 02 (8x35) mm  2 / piece
SG - 01  2 / piece	OT-056D  2 / piece	AVT - 01  6 / piece	KP - 01 (224) mm  2 / piece

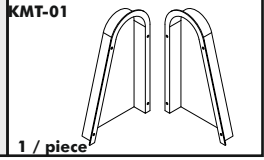
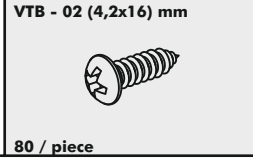
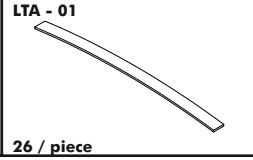
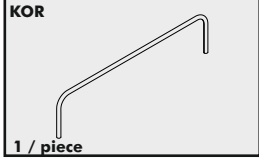
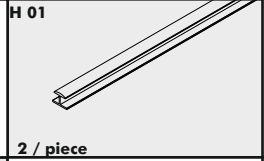
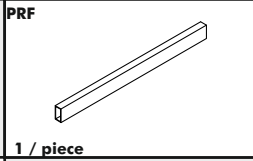
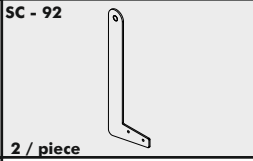
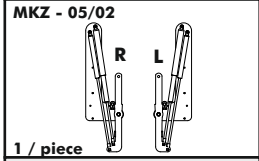
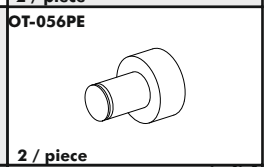
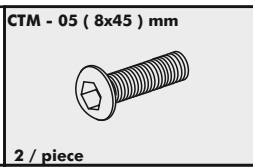
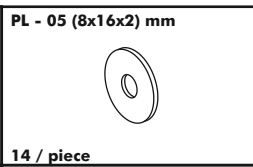
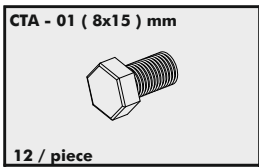
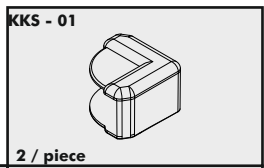
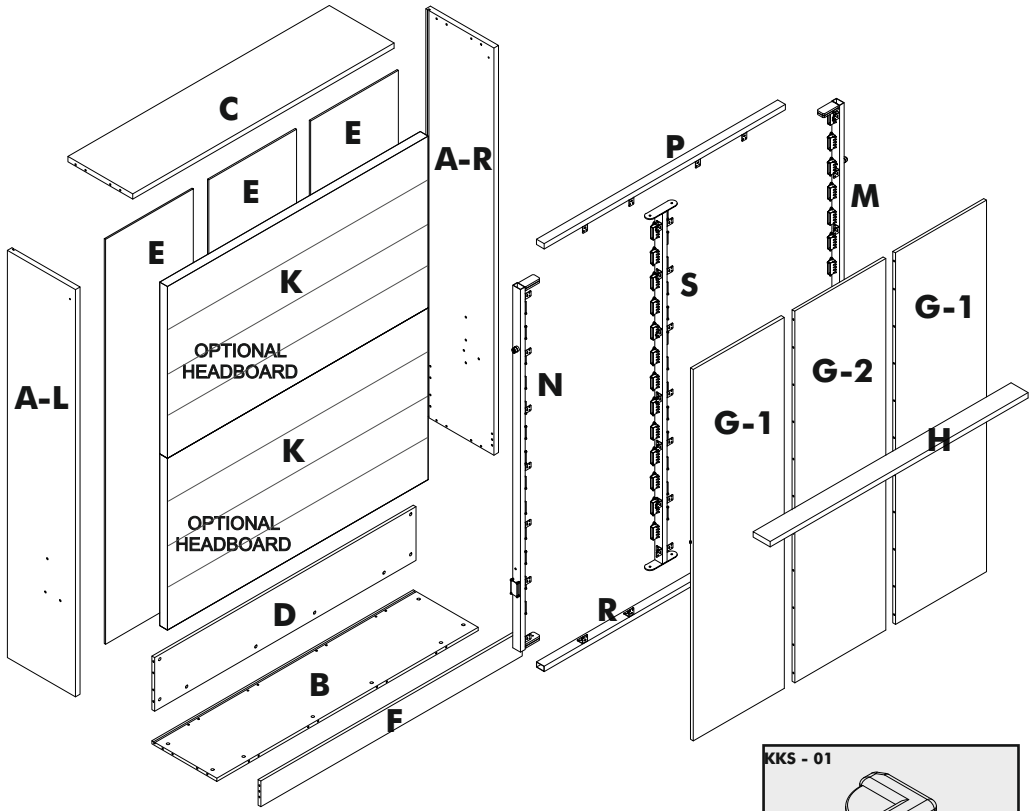

STEP 1



MNX - 02

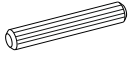

KVL 01

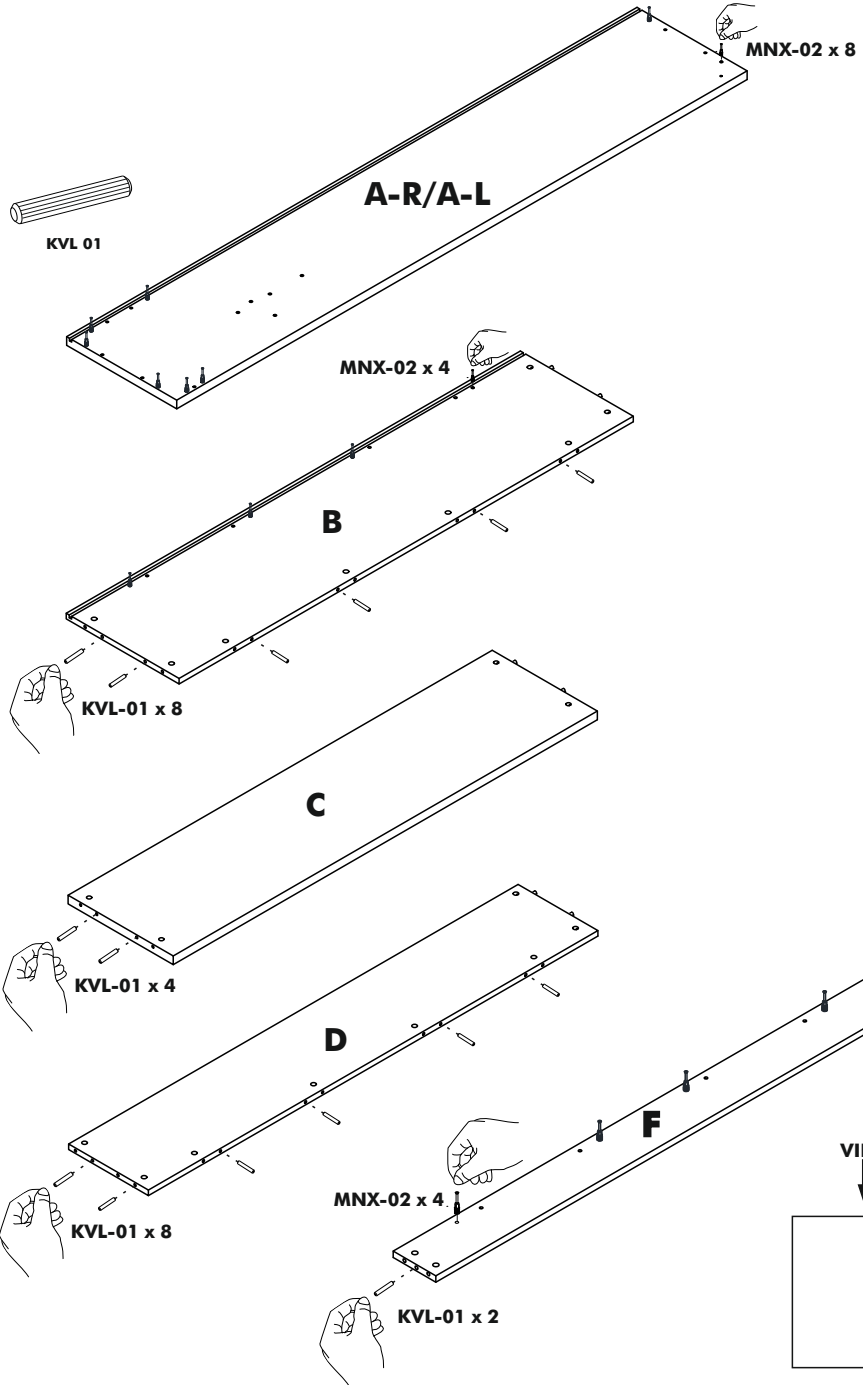

VIDEO

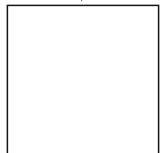

link

STEP 2

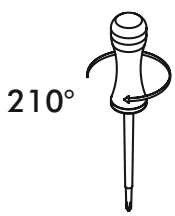

MNG - 01 x 8

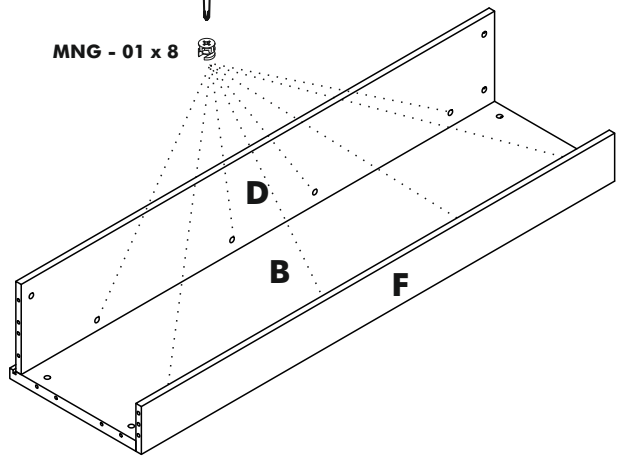

STEP 3



210°

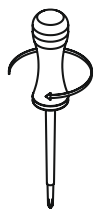

MNG - 01 x 8

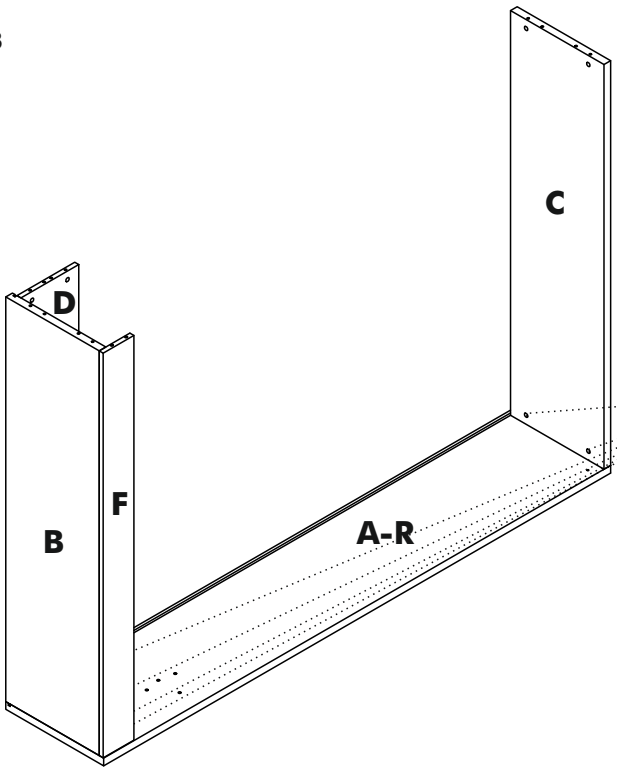

VIDEO

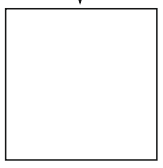

link

STEP 4

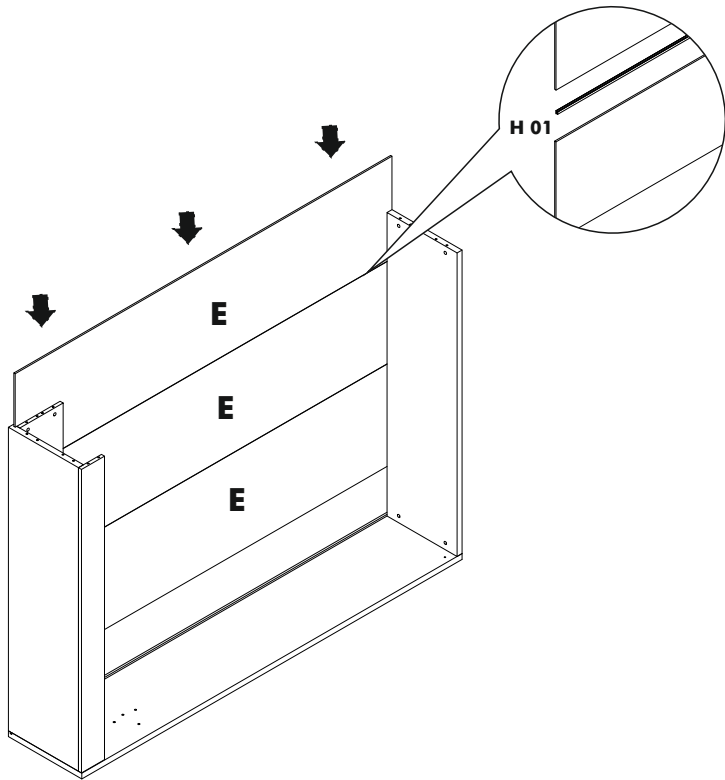

STEP 5

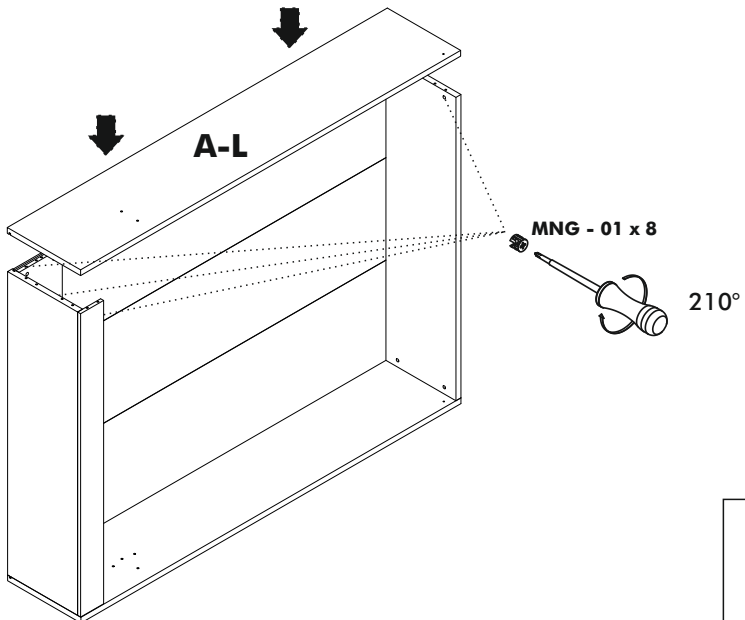

STEP 6

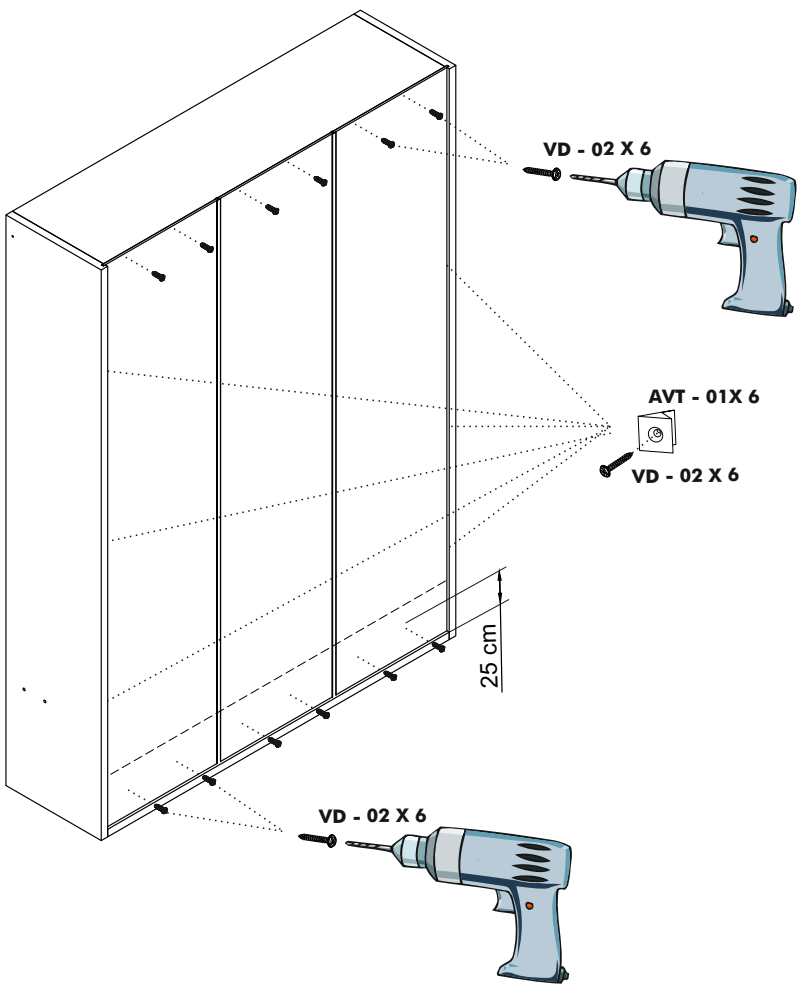

VIDEO

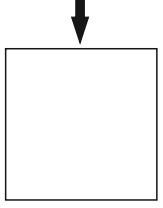

link

STEP 7

**OPTIONAL
HEADBOARD**

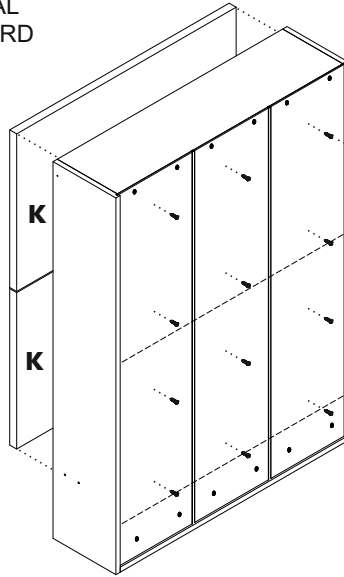
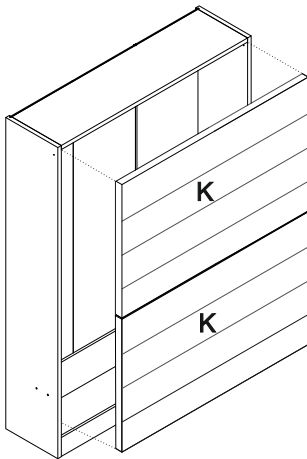

VD - 02x12



STEP 8

DD - 01

Ø 10 mm / 0,254 inch

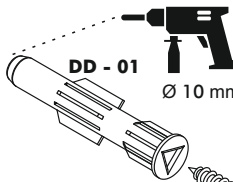

PL - 02

TFC - 01

VTB - 01

DSE - 01

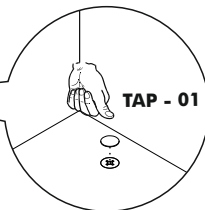
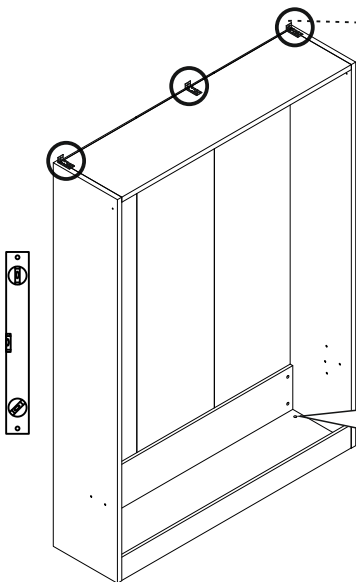

TAP - 01

VIDEO

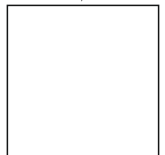

link

STEP 9



KVL 01

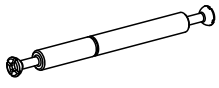

MNX - 03

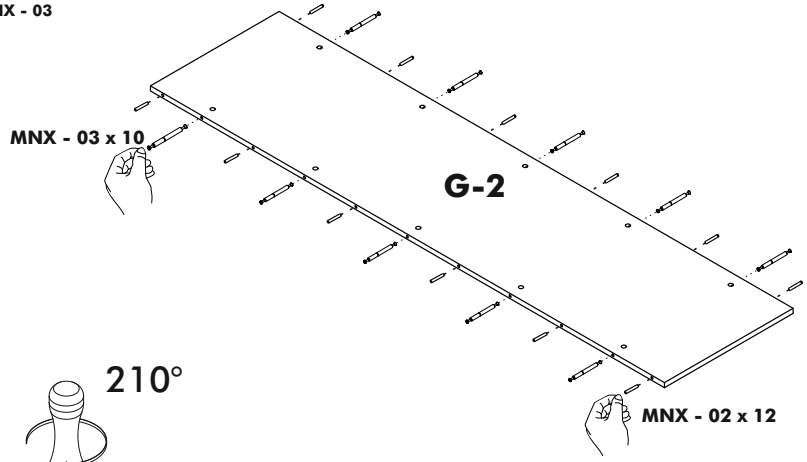

STEP 10



MNG - 01

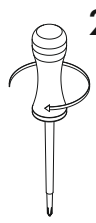

210°



MNG - 01 x 20

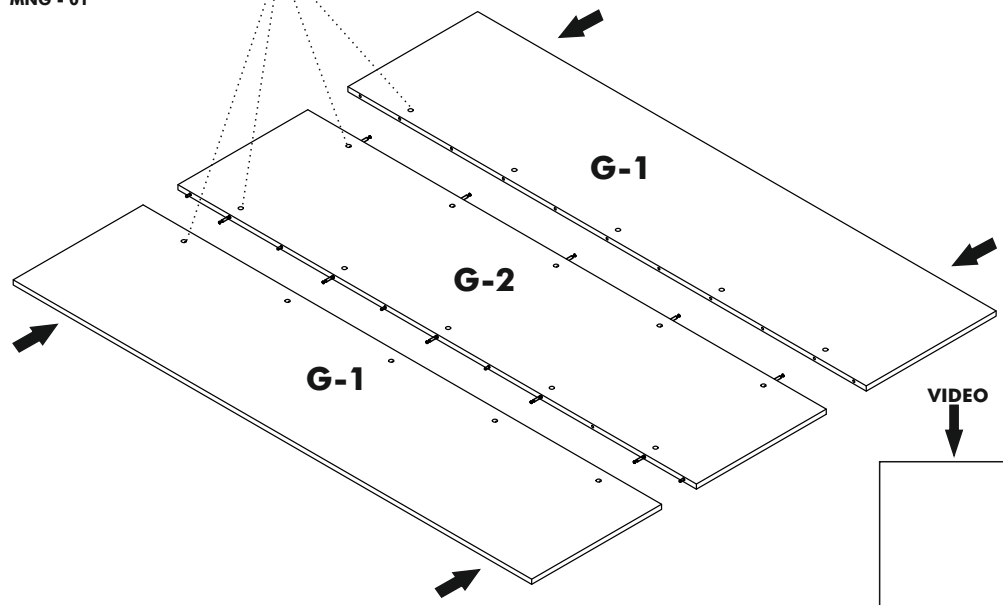

STEP 11

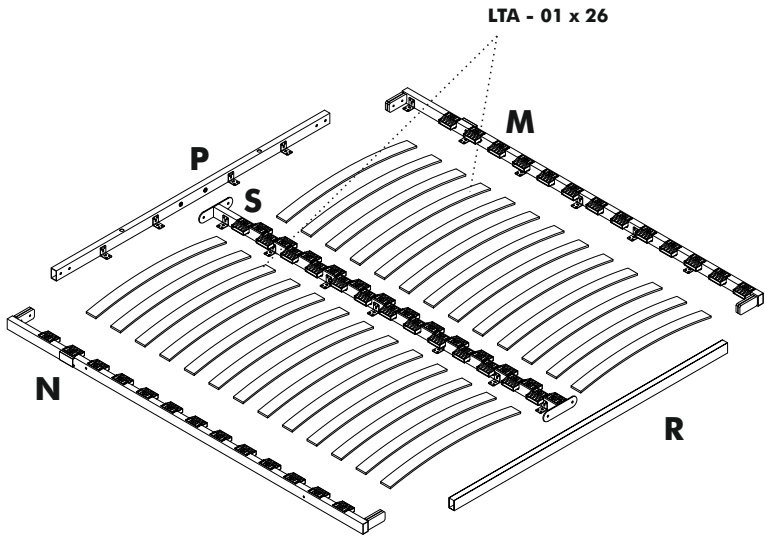

STEP 12

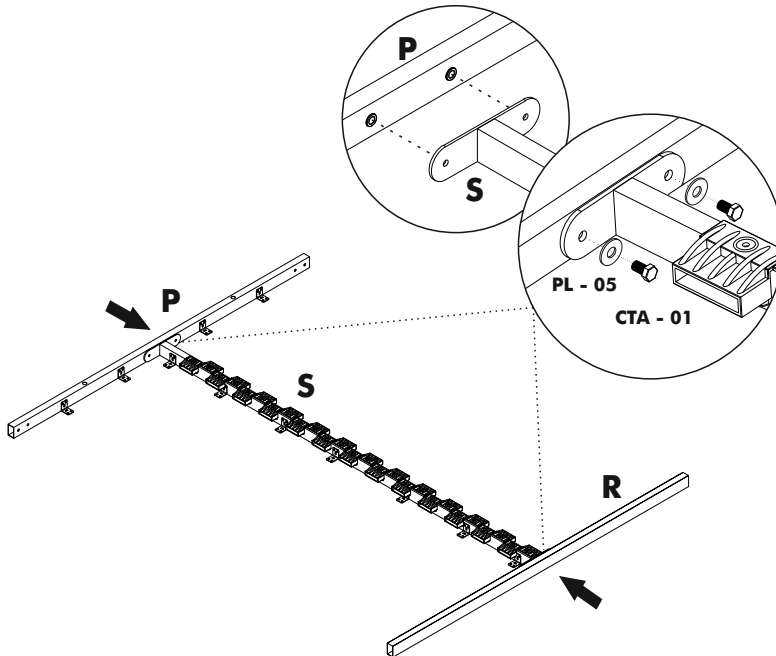

VIDEO

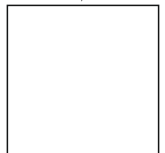

link

STEP 13

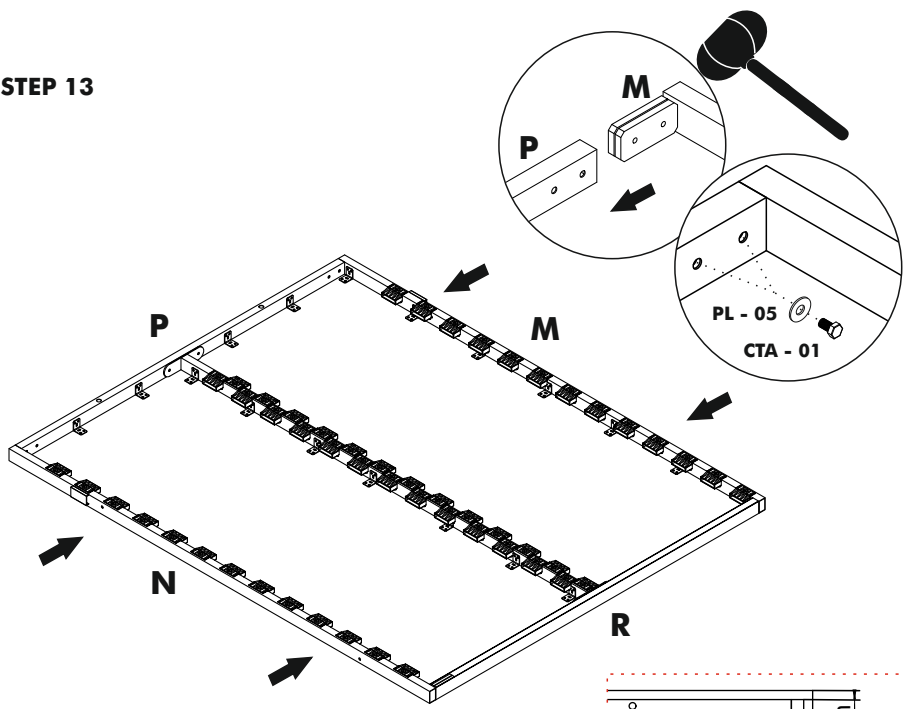

STEP 14

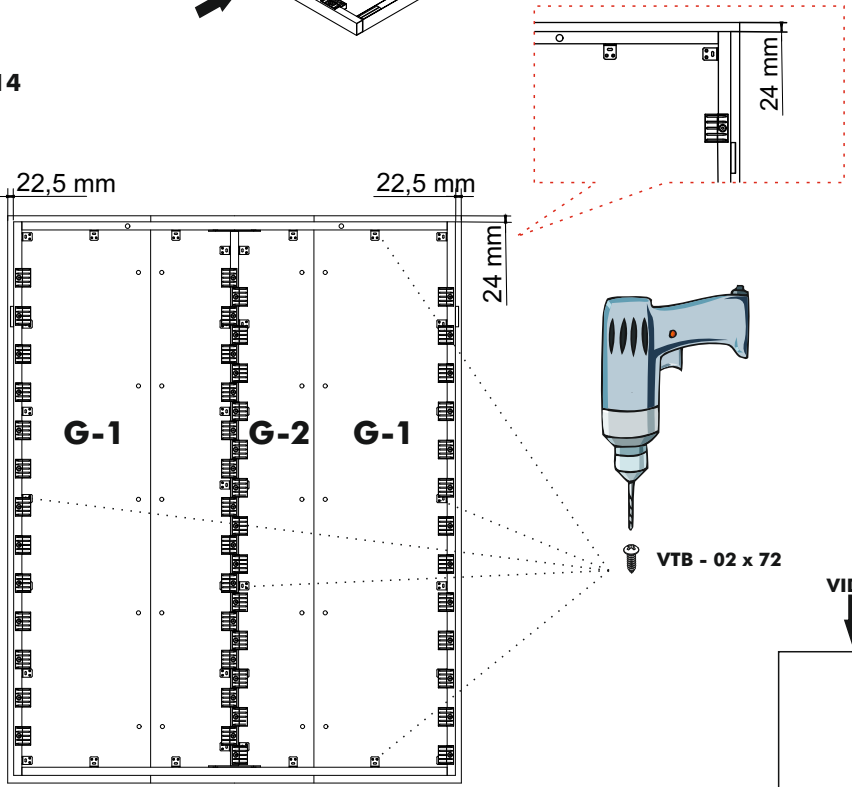

STEP 15

Unscrew the Screws

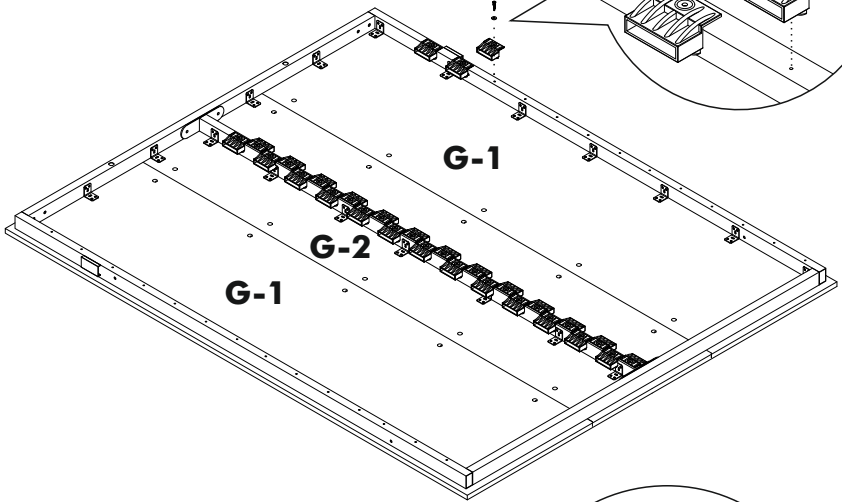

STEP 16

LTA - 01 x 26

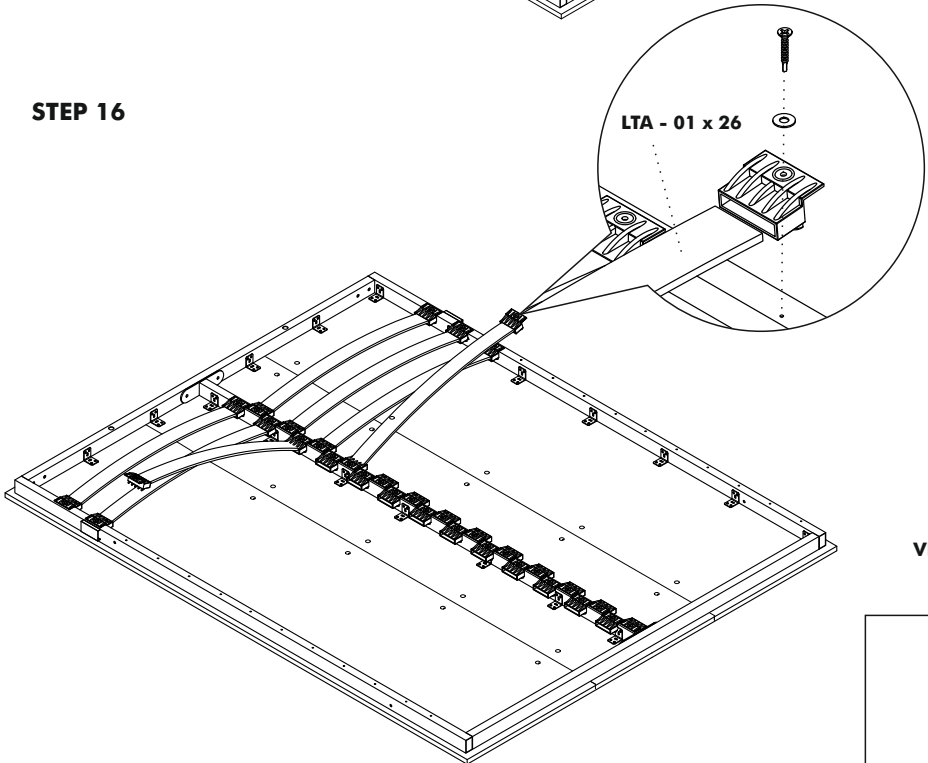

VIDEO



STEP 17

CAUTION
DO NOT UNLOCK BEFORE INSTALL

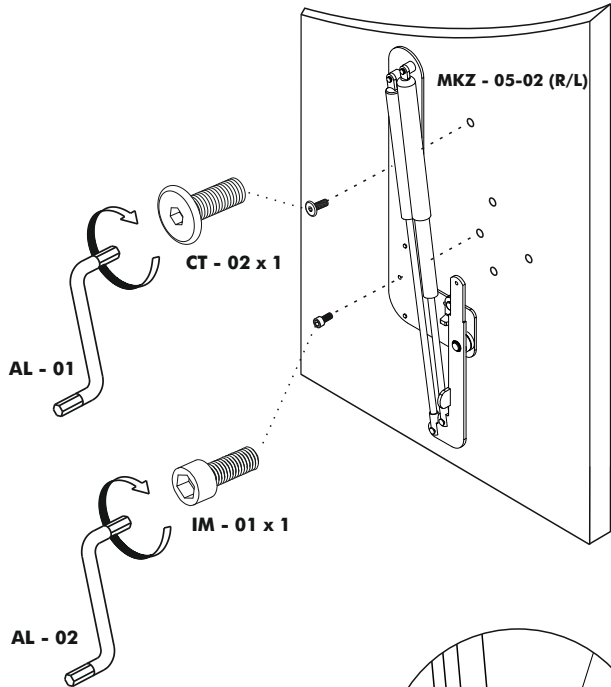
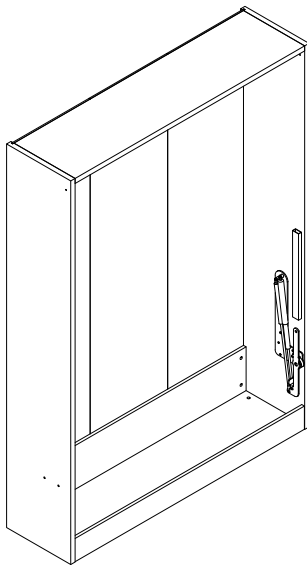

STEP 18

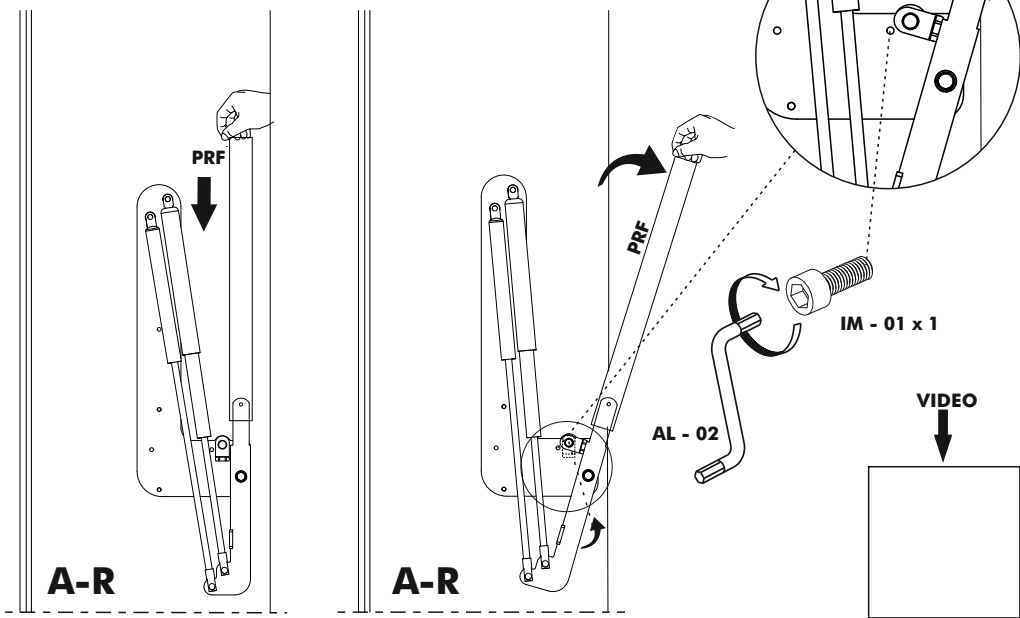

STEP 19

45-50°

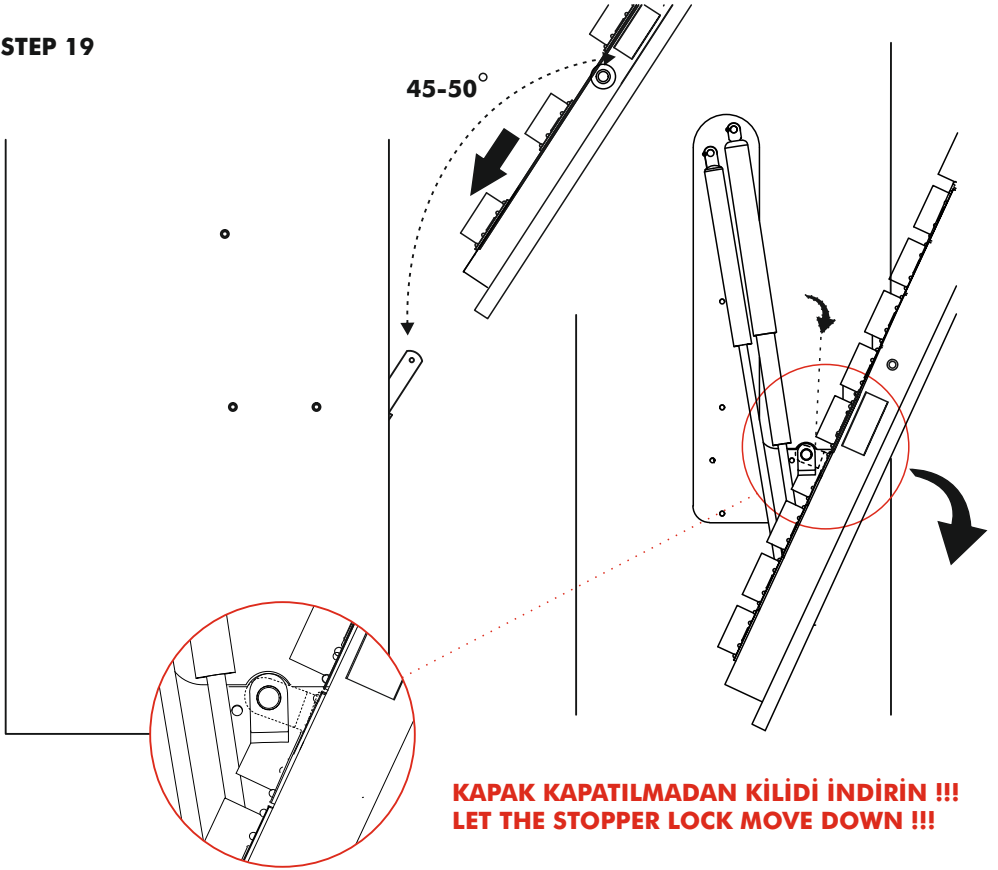

**KAPAK KAPATILMADAN KİLİDİ İNDİRİN !!!
LET THE STOPPER LOCK MOVE DOWN !!!**

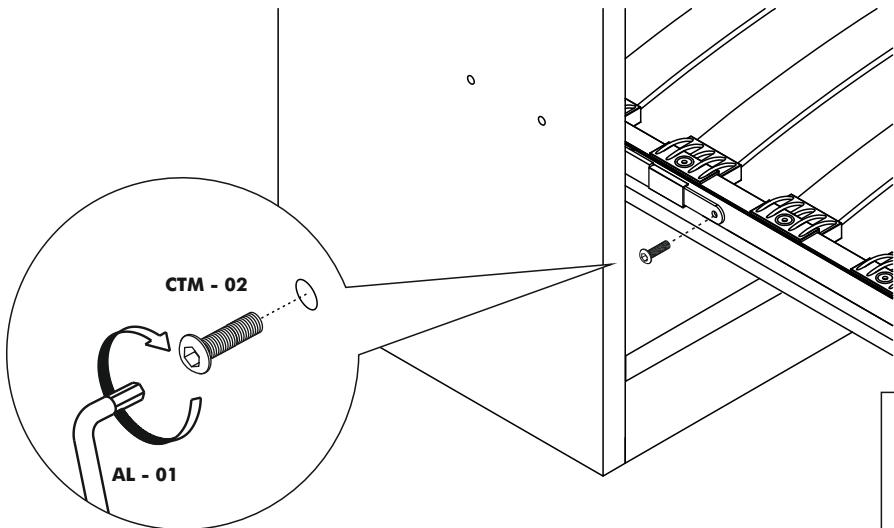

VIDEO



link

STEP 20

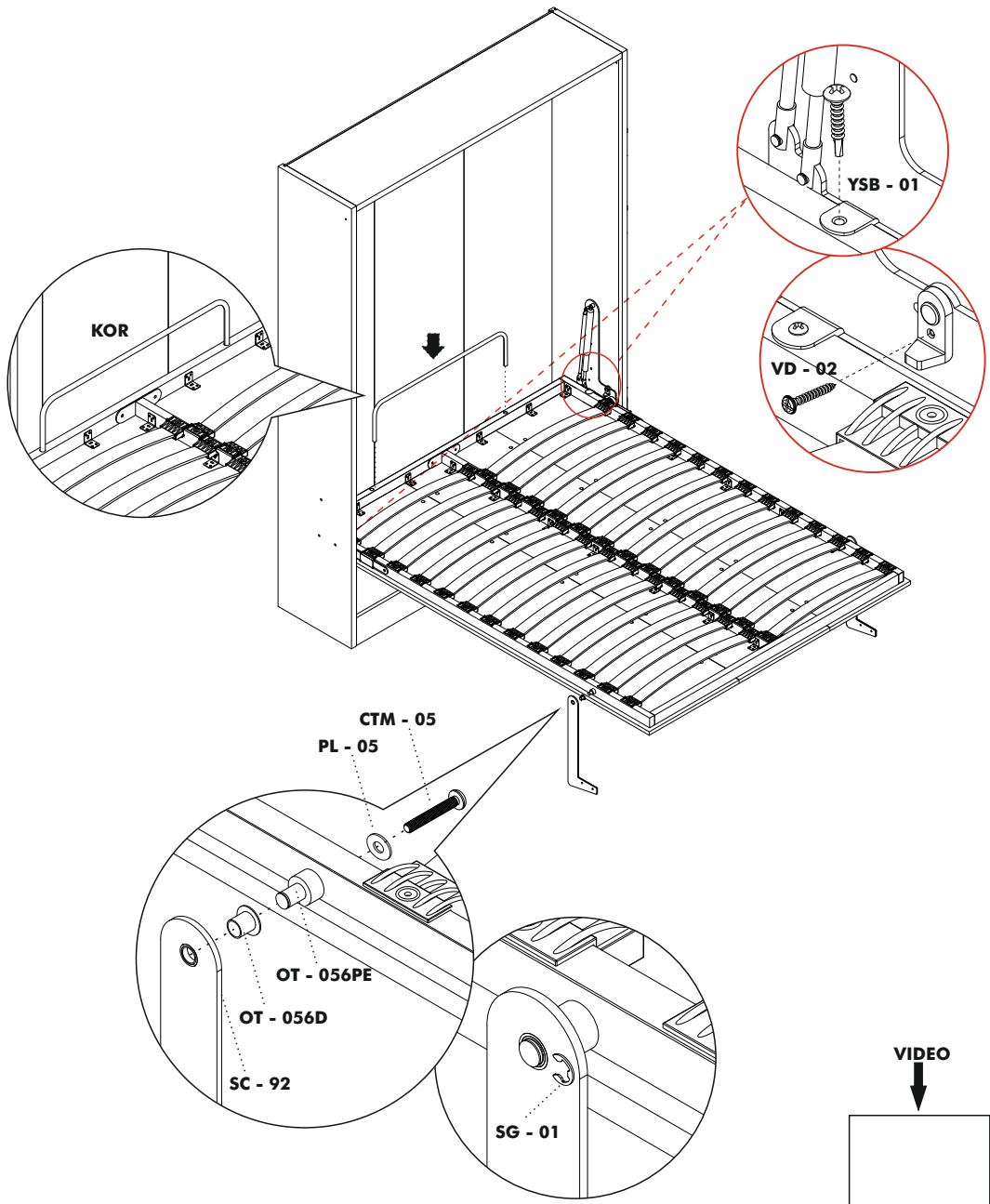

STEP 21

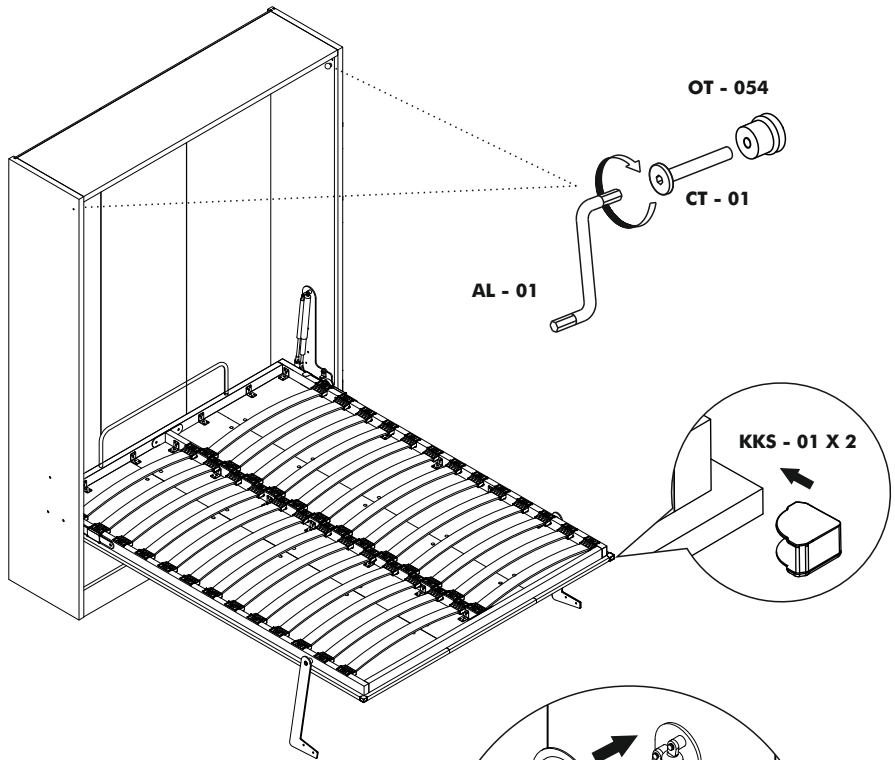

STEP 22

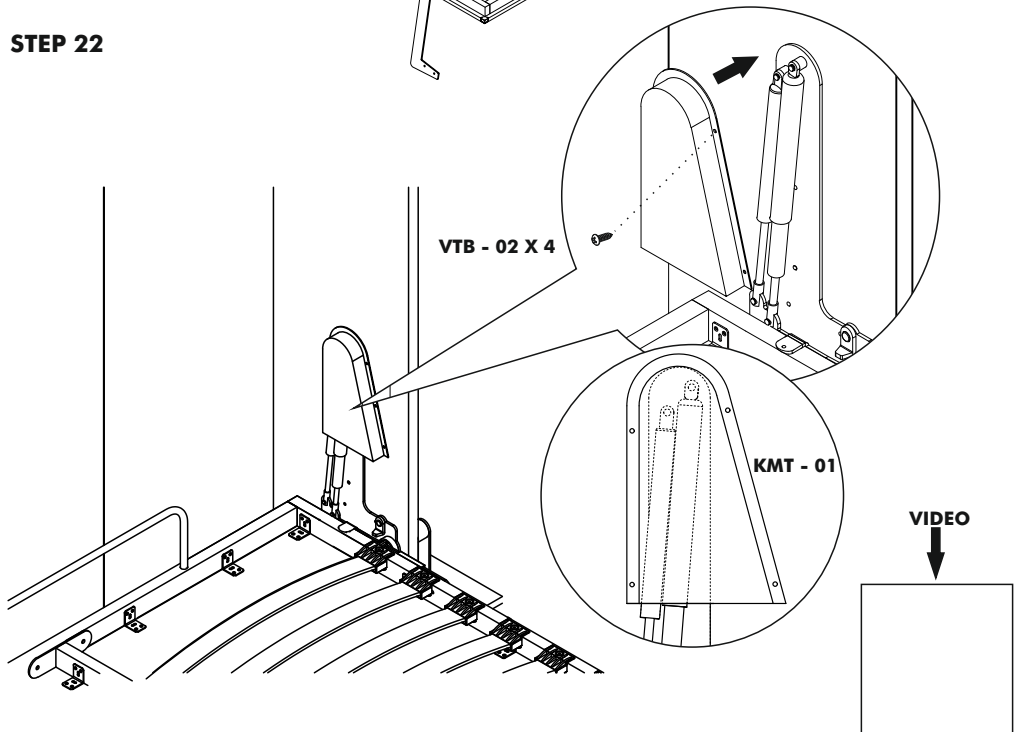

STEP 23

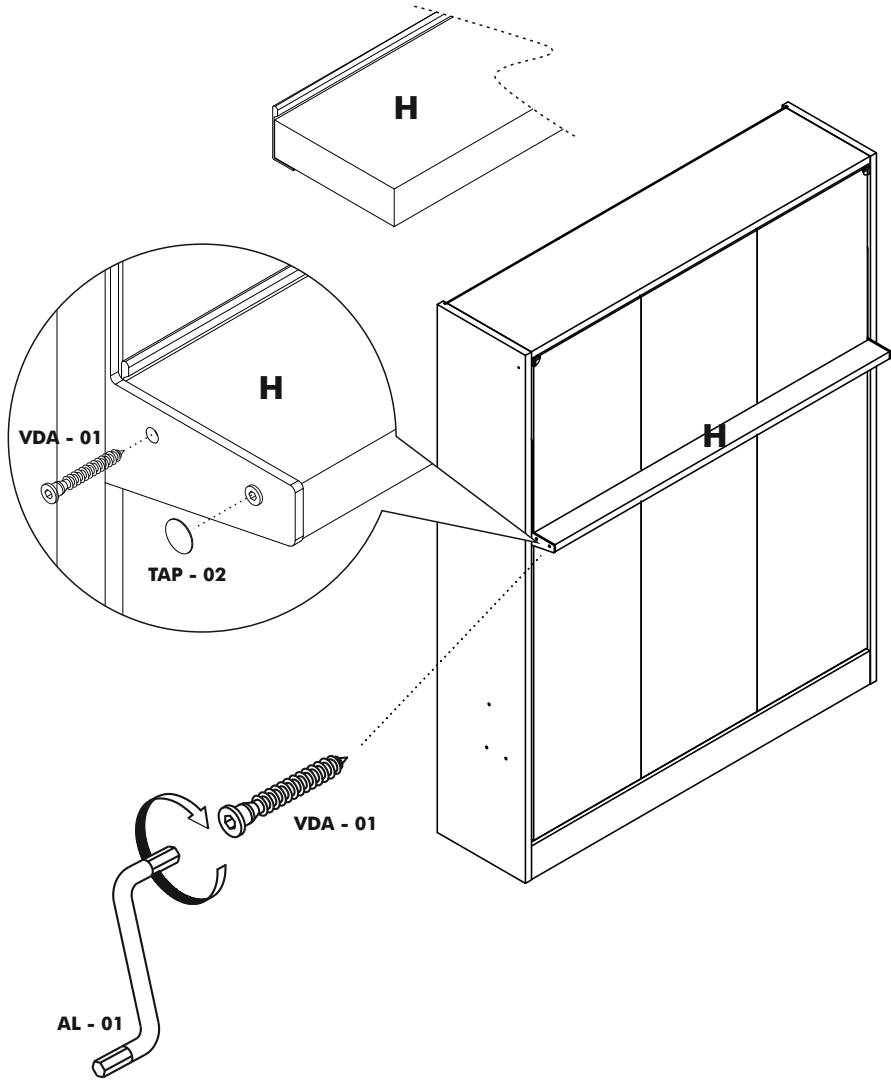

VIDEO
↓

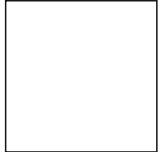

link

STEP 24

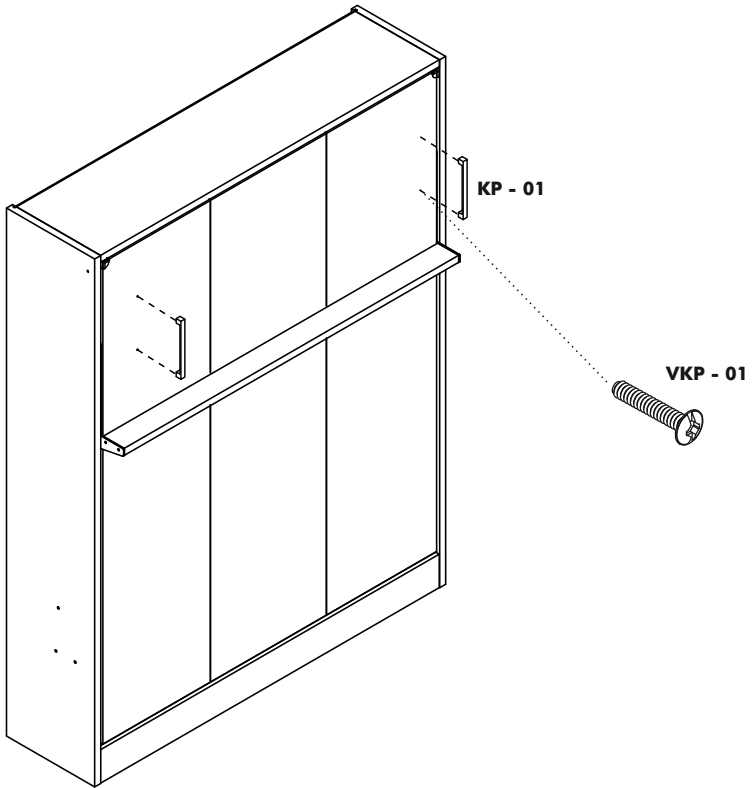

VIDEO

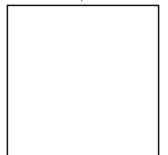

link

ATTENTION / HOW TO / READ ME / OWNER'S GUIDE

1. When mounting on a regular drywall, furniture must be fastened to wood or metal studs. Solid walls made of brick, concrete or similar strong material are also acceptable. Do not mount furniture to paper-mache or sheet rock like material without properly affixing to stud.
2. For safety and product longevity you must periodically inspect the mounting and mechanical connections for integrity and tightness. Confirm hardware remains properly affixed and connections snug.
3. Wall Bed mattress thickness may not exceed 8 inch. Take care to remove pillows and excess blankets before closing. Doing so keeps mechanism free of obstruction and unnecessary stress.
4. Do not lean or rest heavy objects on side or top of furniture. This may cause balance issues and compromise the integrity of your mounting connections.
5. Please use the furniture's beds, desks and shelving as intended. Not designed to be sat, stood, leaned, jumped (etc) on. Improper use may cause personal injury and damage to property.
6. With seasonal humidity change you must inspect interior and exterior of furniture.
7. Single, Twin, Twin XL beds accommodate the weight of one person. Improperly sleeping more than one person risks injury to person and damage to property.
8. Before any un-mounting or disassembly please contact Multimo for technical support and instruction. Failure to properly detach risks injury to person and damage to property.
9. For Bunk Beds:
 - a. Always use provided ladder when accessing top bunk.
 - b. Be slow, careful and aware of surroundings when opening top bunk.
 - c. Do not horseplay. Beds are to be slept on only.
 - d. Some have legs that fully extend when open- be aware of where the leg is and will be.



MULTiMO

www.multimo.com