

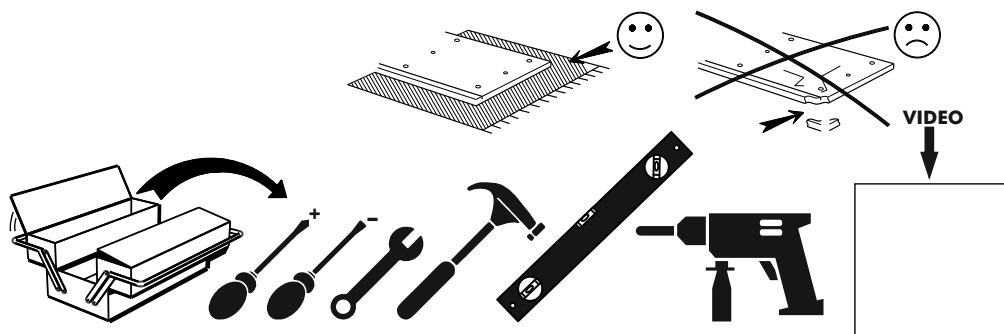

# MULTIMO

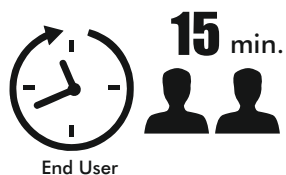

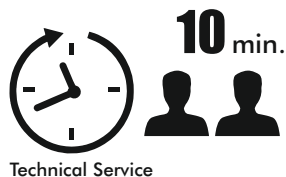

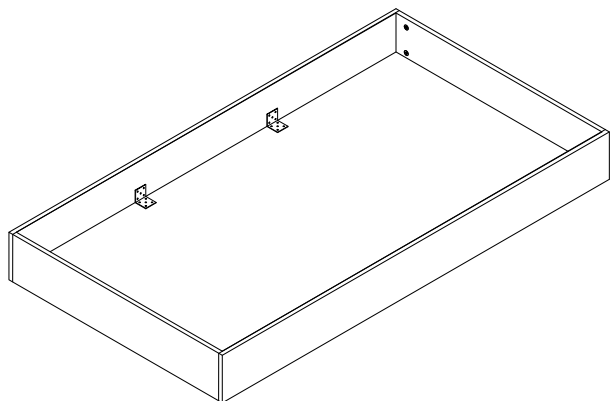

## 730-4 PRIMER TWIN BUNK BOTTOM CHEST

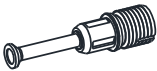

link

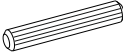
Track Title	Piece	(inch)			(mm)			
		Thickness	Length	Width	Piece	Thick	Height	Most
<b>A</b>		0,71	77,95	7,09	2	18	1980	180
<b>B</b>		0,71	35,43	7,09	2	18	900	180
<b>C</b>		0,71	77,13	36,10	1	18	1959	917

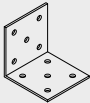
### Accessories List

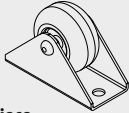
<b>MXN 02</b>  <b>8 / piece</b>	<b>MNG - 01</b>  <b>8 / piece</b>	<b>KVL 01</b>  <b>8 / piece</b>	<b>VTB - 01 (4,8x16) mm</b>  <b>44 / piece</b>
<b>KB - 01</b>  <b>4 / piece</b>	<b>TAP - 01</b>  <b>8 / piece</b>	<b>TKR-01 ( 32 ) mm</b>  <b>6 / Piece</b>	

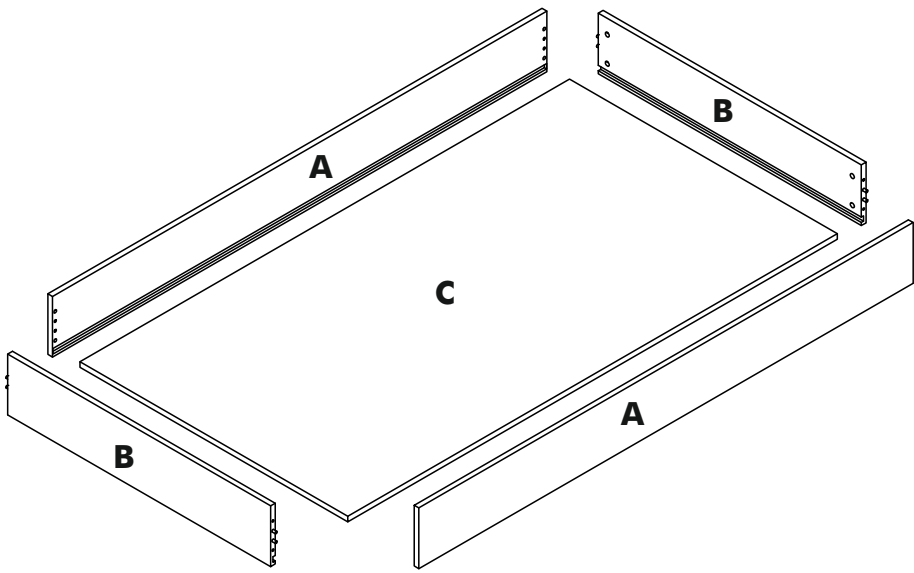

**STEP 1**



**MNX - 02**

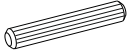

**KVL - 01**

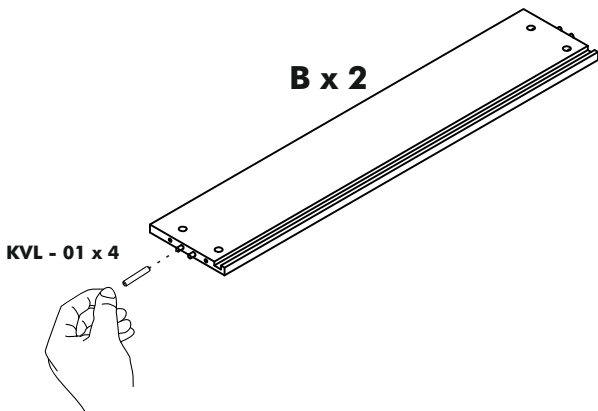
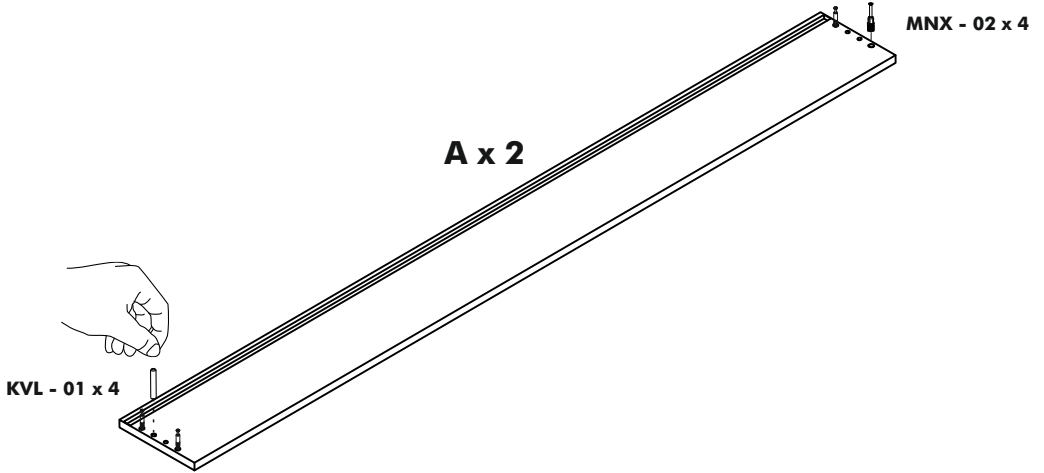

**VIDEO**

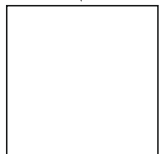

link

**STEP 2**

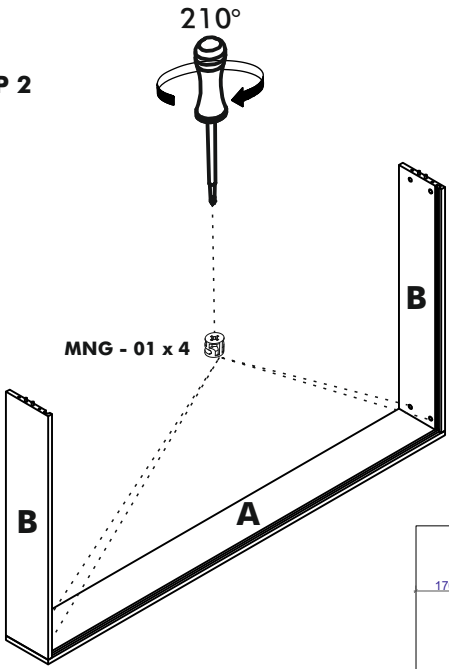

**DIMENSIONS**

170	170	809.5	809.5	170	170
577	170	809.5	809.5	170	170

**STEP 3**

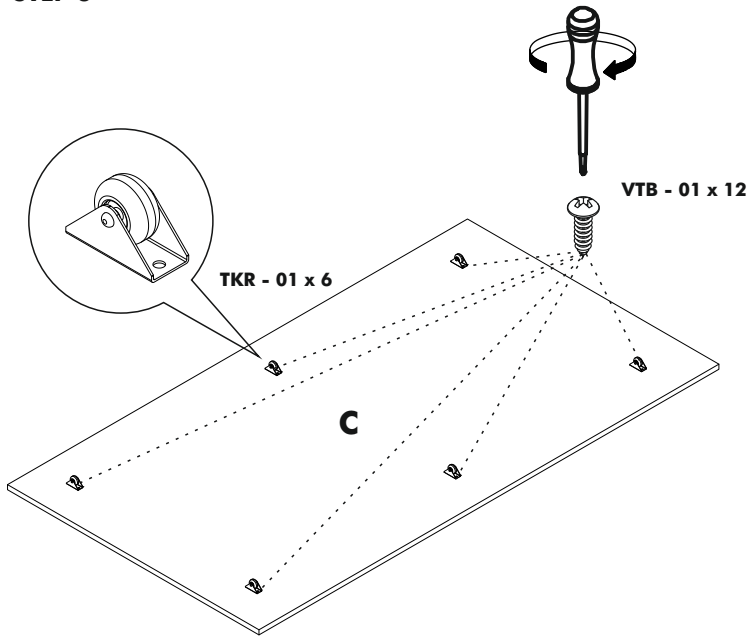

**VIDEO**

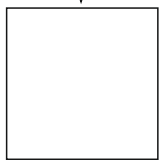

link

**STEP 0**

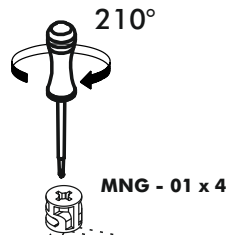

**STEP 4**

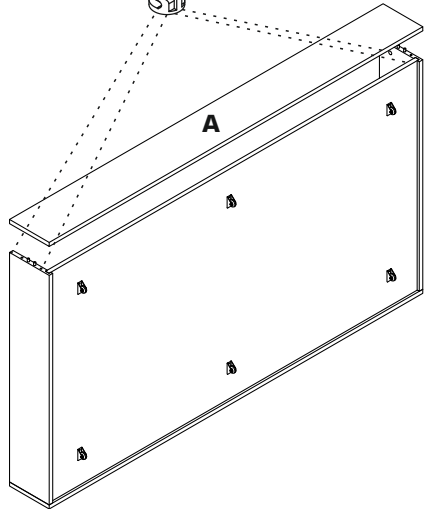
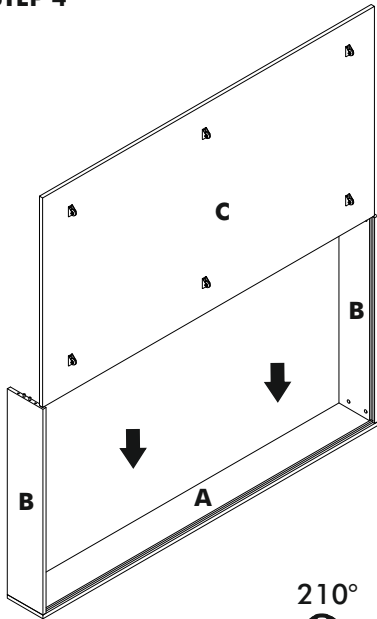

**STEP 5**

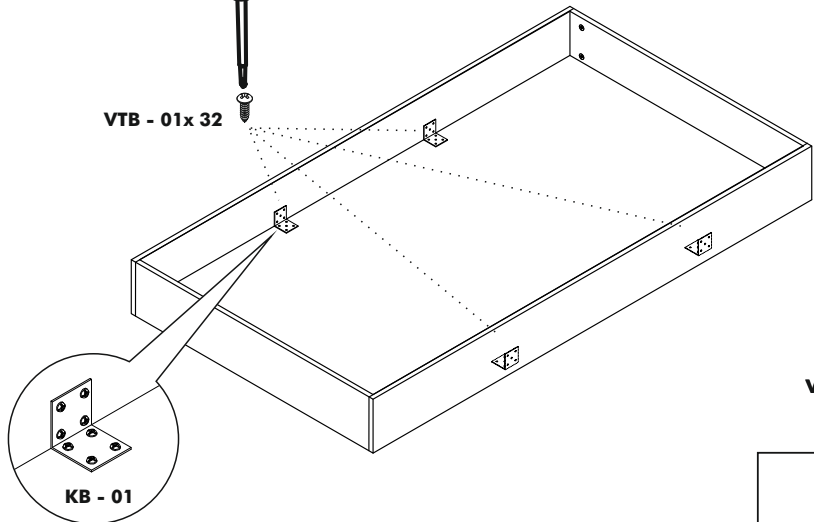
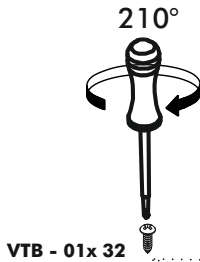

**VIDEO**

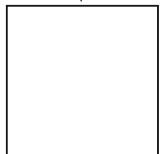

link

**STEP 6**

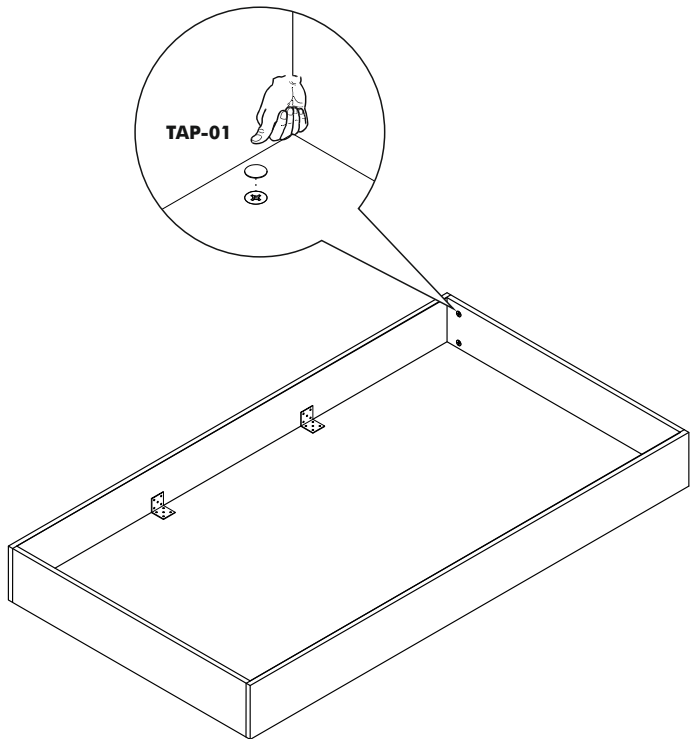

**VIDEO**

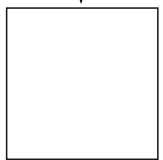

link



**MULTiMO**

[www.multimo.com](http://www.multimo.com)