

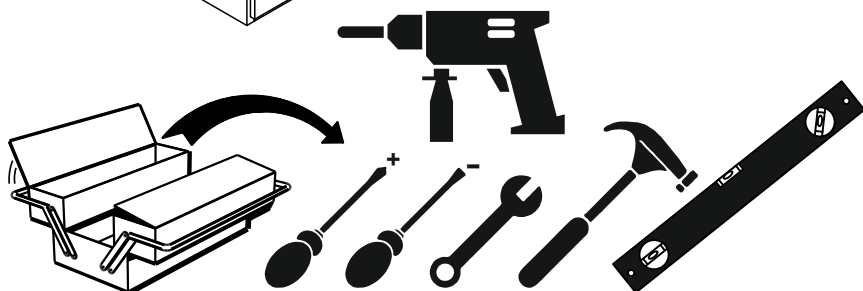

MULTIMO

220- ROYAL CONVERTIBLE CABINET

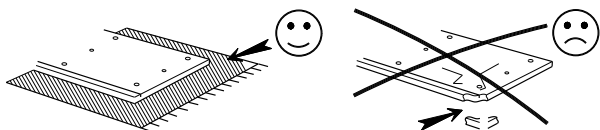

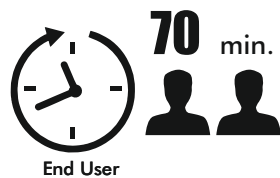
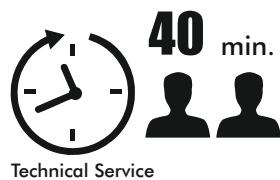
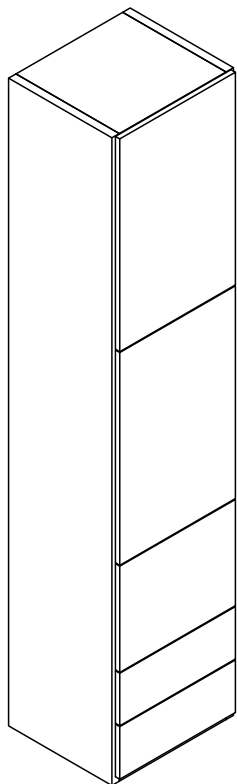

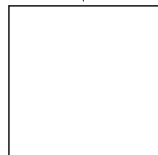





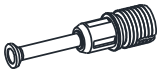

VIDEO

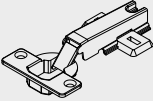
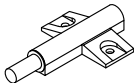
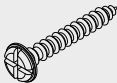
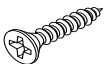
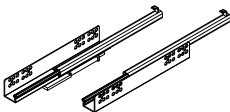

link

Track Title	Piece	(inch)			(mm)			
		Thickness	Length	Width	Piece	Thick	Height	Most
A-R / A-L	2	1,18	89,76	16,54	2	30	2280	420
B	2	1,18	17,09	16,54	2	30	434	420
C	1	1,18	17,09	15,75	1	30	434	400
D	4	1,18	17,09	15,55	4	30	434	395
E	2	0,71	29,49	18,50	2	18	749	470
F	1	0,71	14,72	18,50	1	18	374	470
G	1	0,31	88,03	17,72	1	8	2236	450
H	2	7,28	18,50	14,49	2	185	470	368

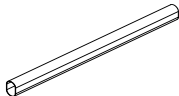
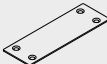
Accessories List

MXN 02  12 / piece	MNG - 01  12 / piece	TAP - 01  12 / piece	KVL 01  12 / piece
TS - 01  6 / piece	BS - 01  3 / piece	VD - 02 (3,5x25) mm  6 / piece	VD - 03 (3,5x18) mm  34 / piece
RYB - 03  2 / piece	ER - 01  8 / piece	PM - 01  16 / piece	AVT - 01  4 / piece
AF - 02  2 / piece	BO - 01  1 / piece	BRK - 01  2 / piece	VTB - 01 (4,8x16) mm  8 / piece

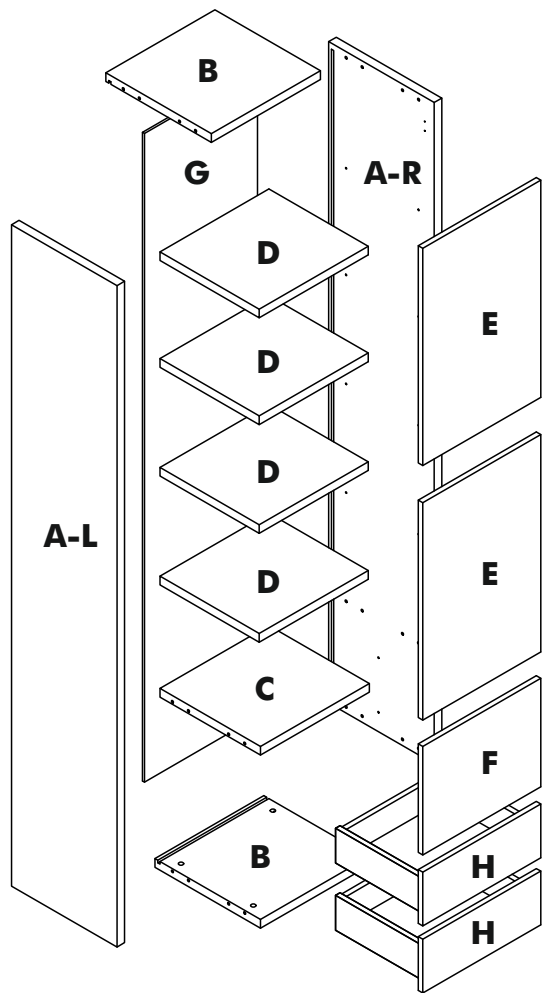

STEP 1



MNX - 02

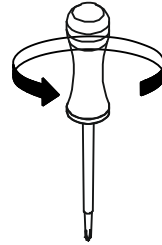

ER - 01 X 4

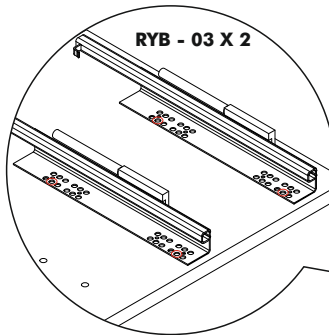

A

**TRACK TITLE
A LEFT / A RIGHT**

VIDEO

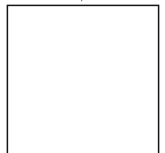

link

STEP 2

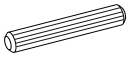

KVL 01

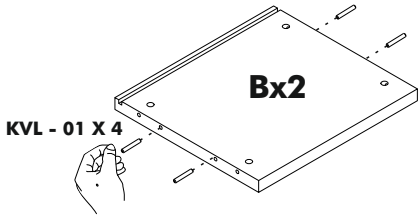

KVL - 01 X 4

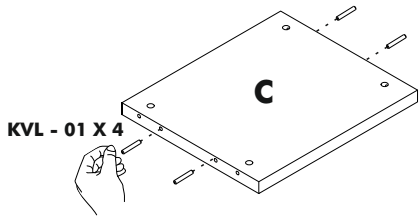

KVL - 01 X 4

STEP 3



MNG - 01

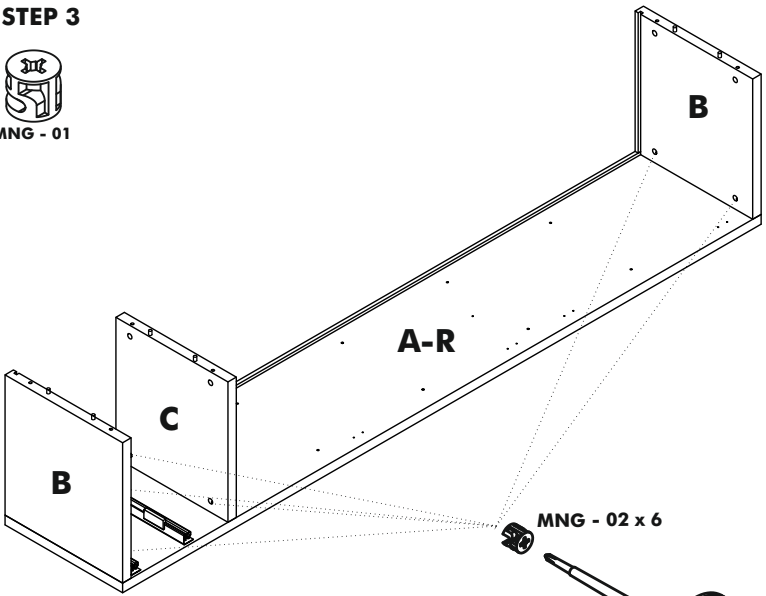

MNG - 02 x 6



210°

VIDEO

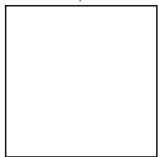

link

STEP 4

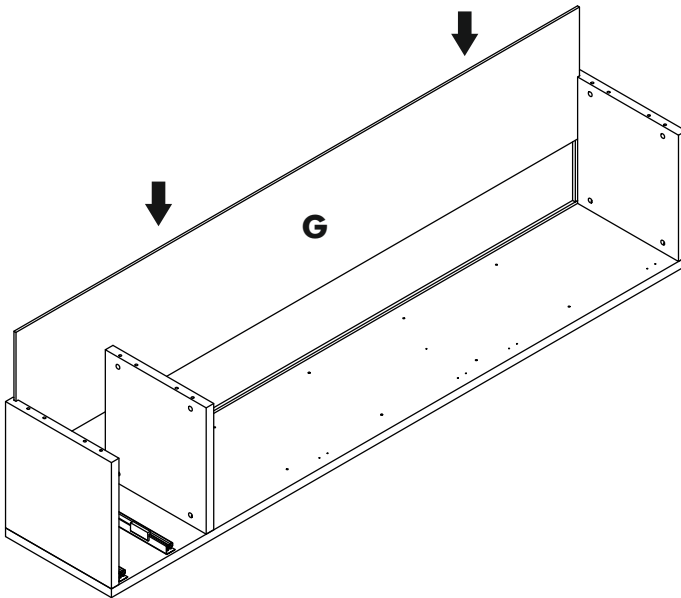

STEP 5

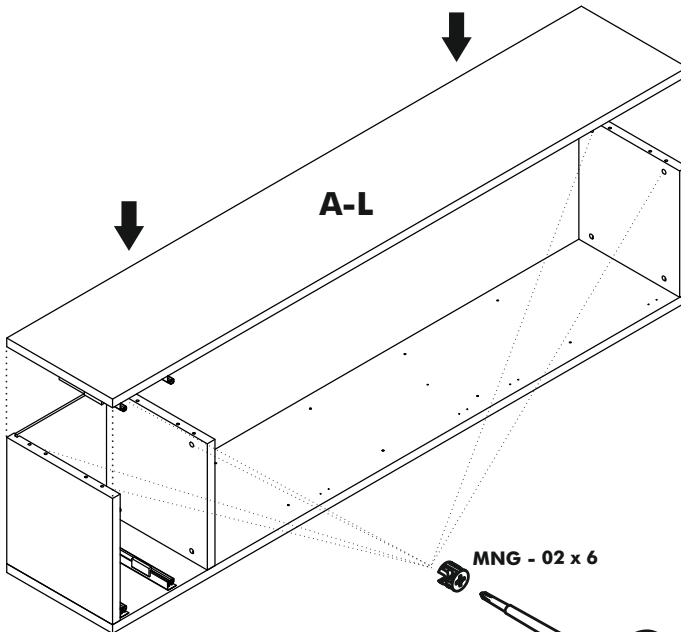

MNG - 02 x 6

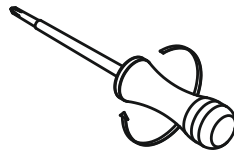

210°

VIDEO

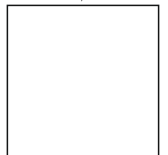

link

STEP 6

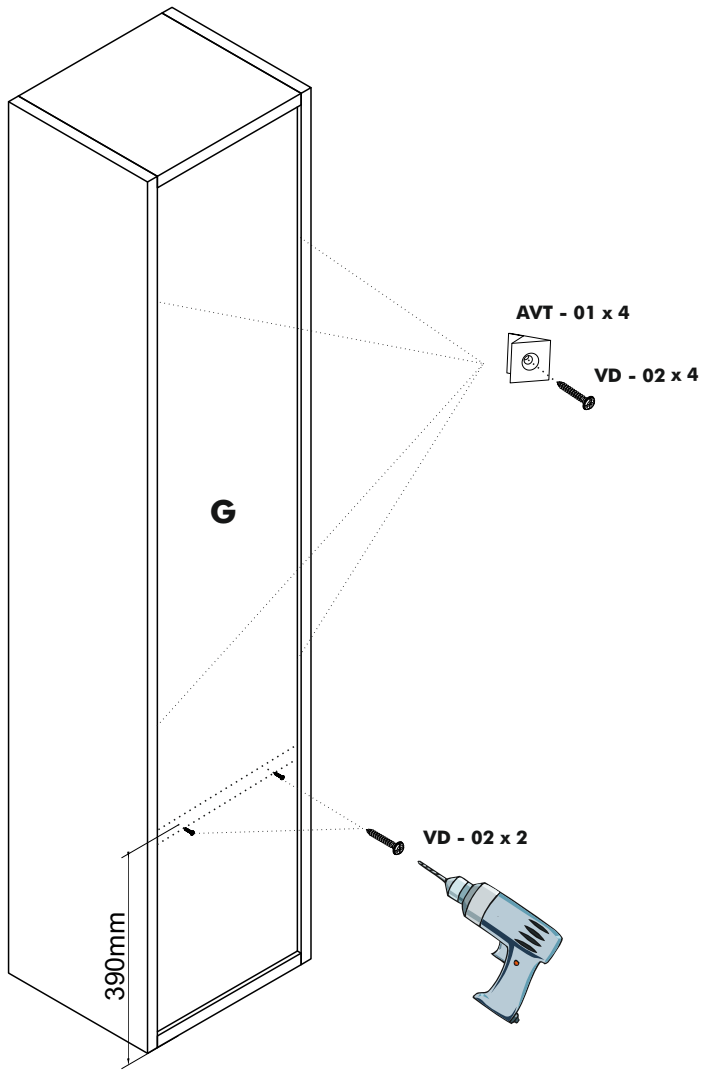

VIDEO

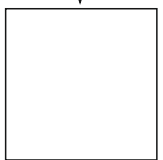

link

STEP 7

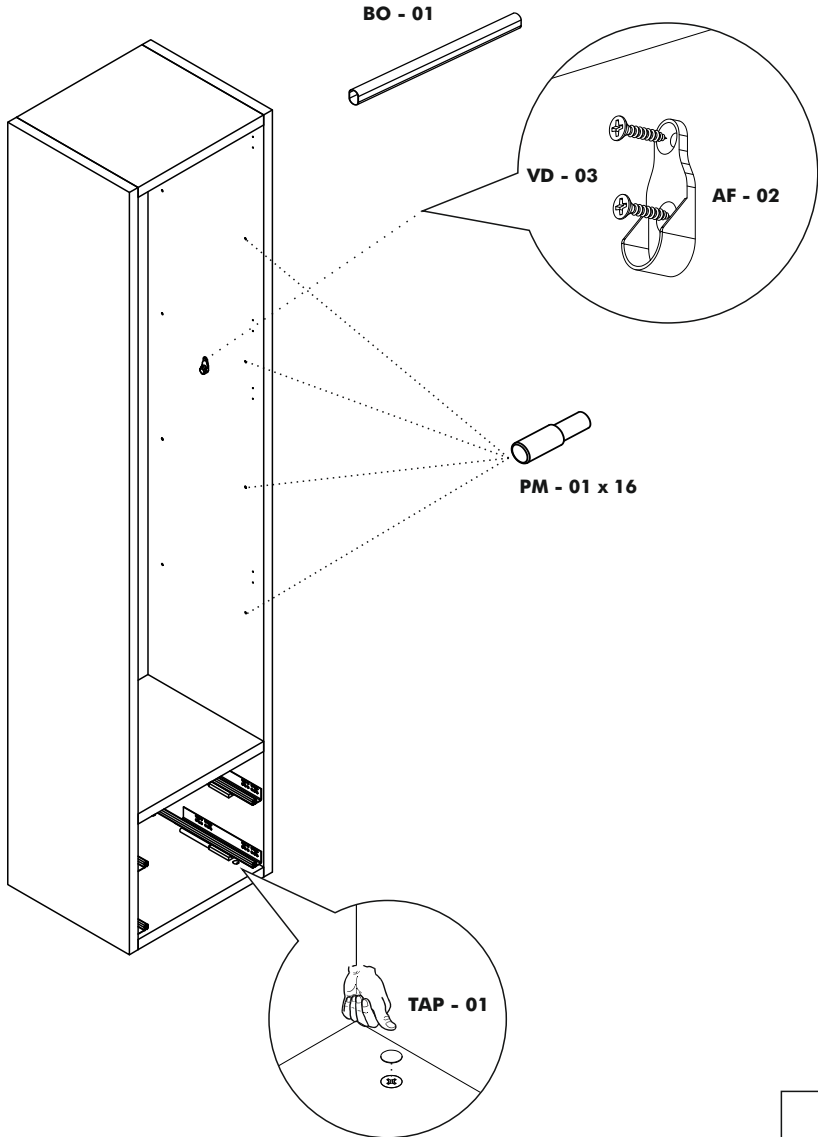

VIDEO

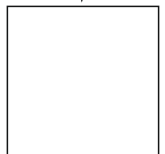

link

STEP 8

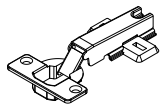

TS - 01

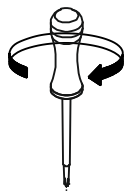

VD - 03 x 12

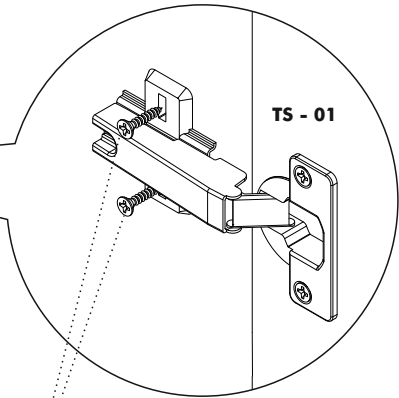
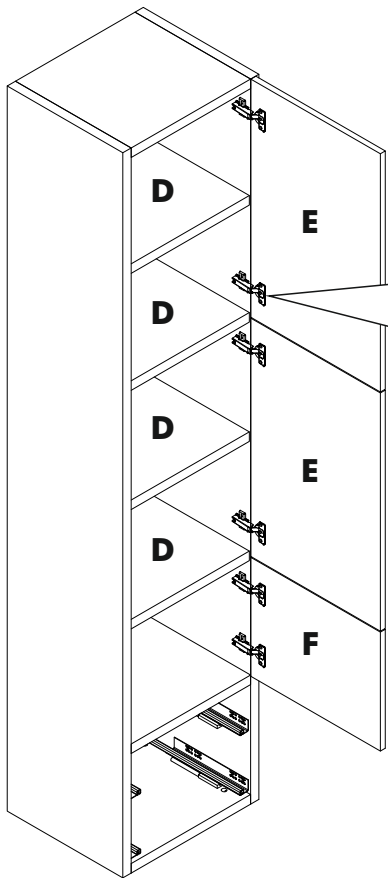
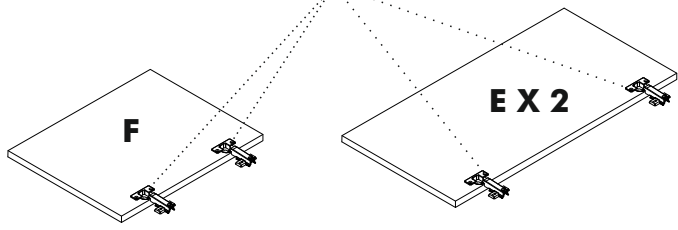

TS - 01

VD - 03 x 2

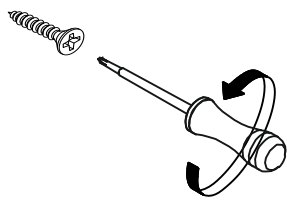

VIDEO

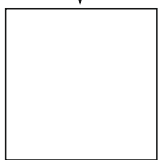

link

STEP 9

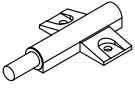

BS - 01

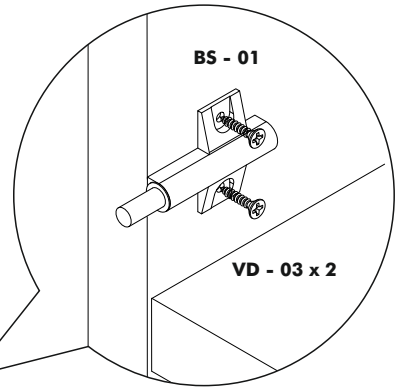
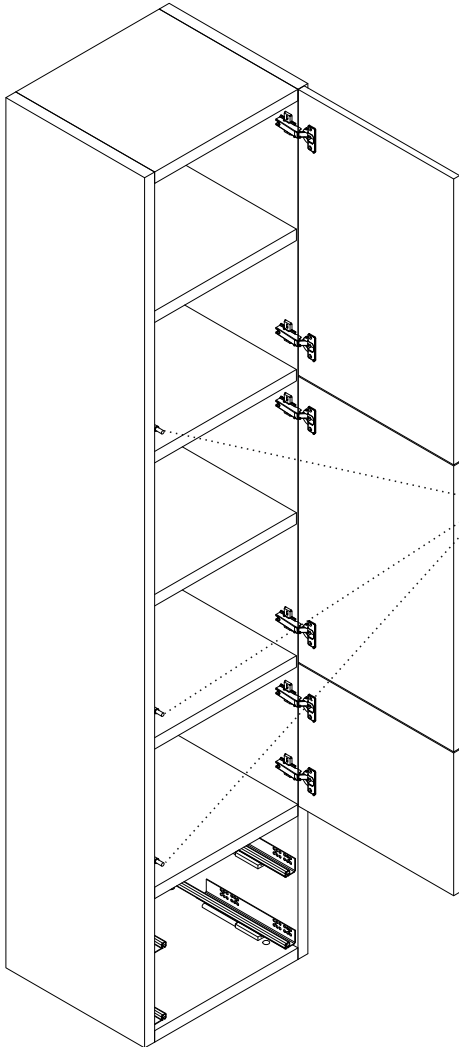

VIDEO

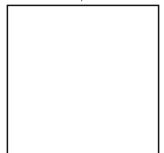

link

STEP 10

Yapıştırırmadan önce yüzeyin tozlu olmadığından emin olun

Before sticking , make sure that the surface is not dusty

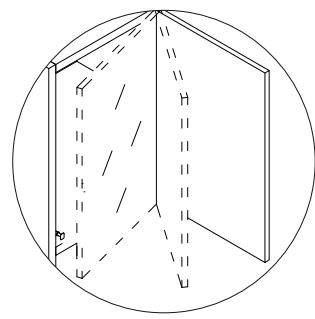
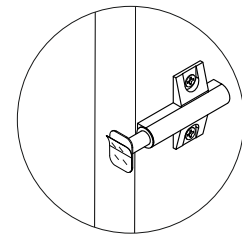
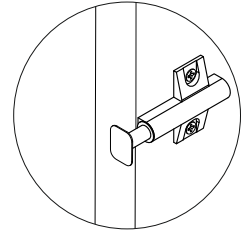
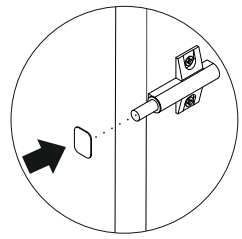
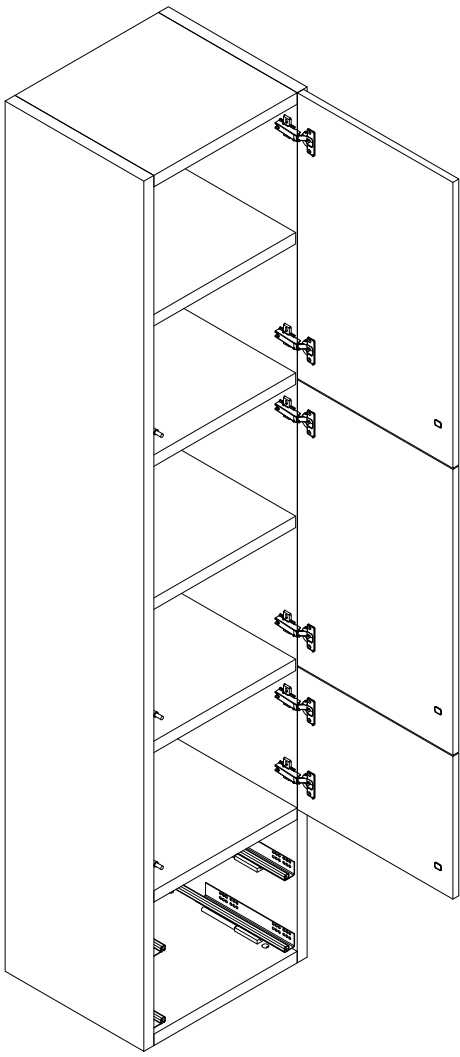

VIDEO

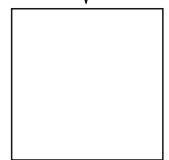

link

STEP 11

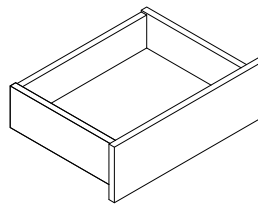
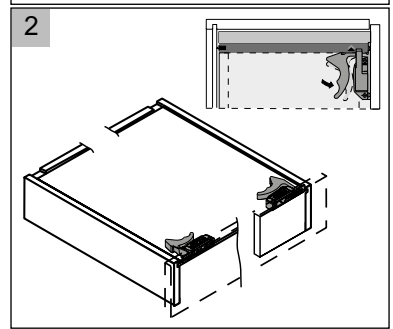
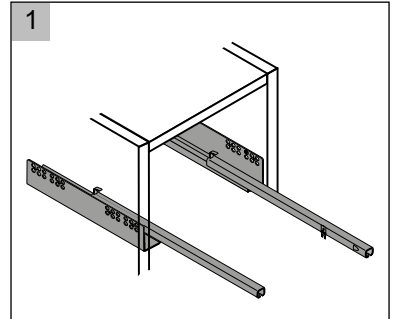
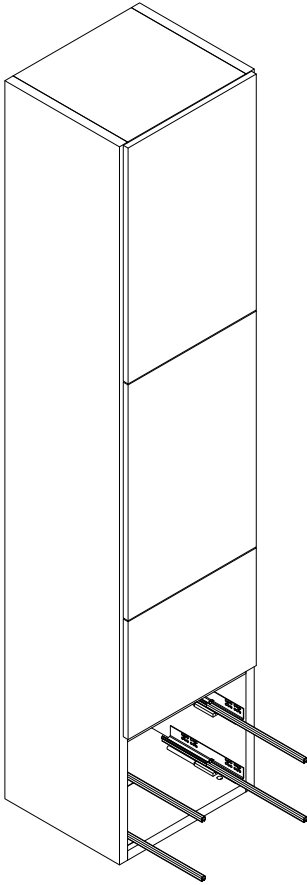

H x 2

VIDEO

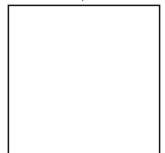

link

STEP 12

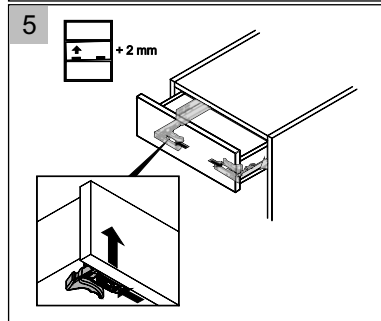
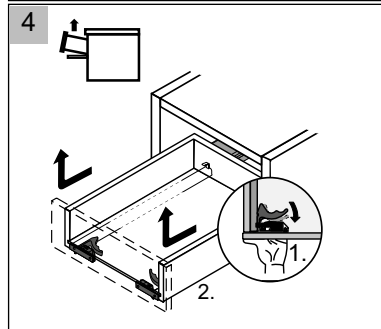
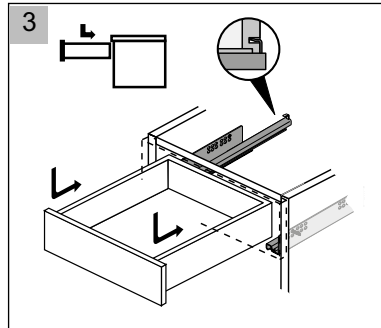
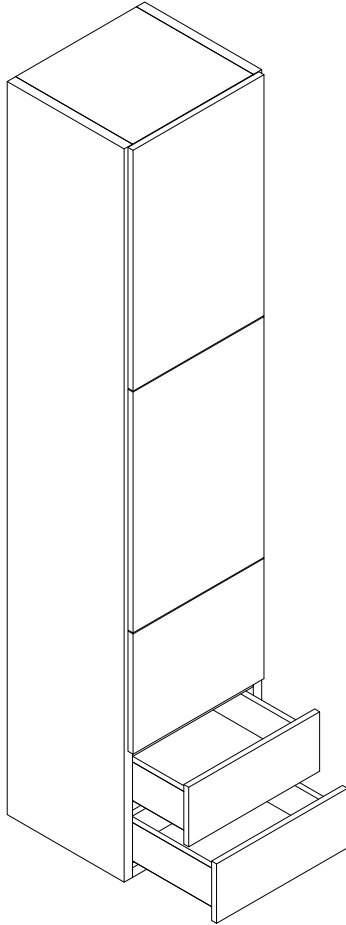

VIDEO
↓

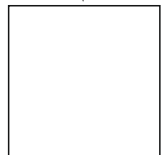

link

STEP 13

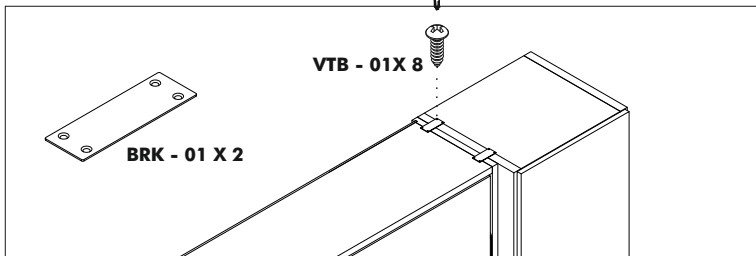
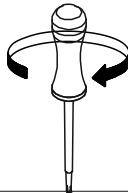
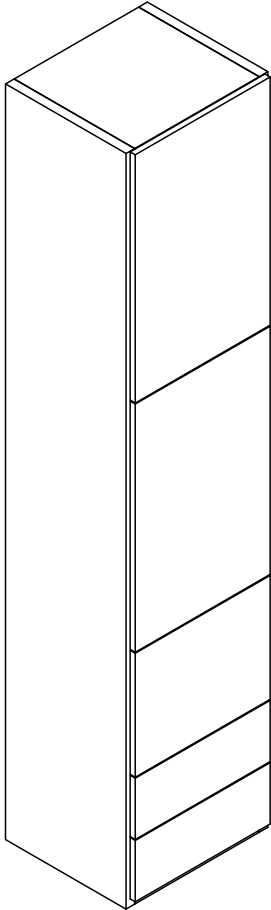

VIDEO

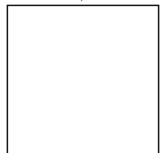

link

ATTENTION / HOW TO / READ ME / OWNER'S GUIDE

1. When mounting on a regular drywall, furniture must be fastened to wood or metal studs. Solid walls made of brick, concrete or similar strong material are also acceptable. Do not mount furniture to paper-mache or sheetrock (plasterboard) like material without properly fixing to stud.
2. For safety and product longevity you must periodically inspect the mounting and mechanical connections for integrity and tightness. Confirm hardware remains properly affixed and connections snug.
3. Wall Bed mattress thickness may not exceed 8 inches (200mm). Take care to remove pillows and excess blankets before closing. Doing so keeps mechanism free of obstruction and unnecessary stress.
4. Do not lean or rest heavy objects on side or top of furniture. This may cause balance issues and compromise the integrity of your mounting connections.
5. Please use the furniture's beds, desks and shelving as intended. Not designed to be sat, stood, leaned, jumped (etc) on. Improper use may cause personal injury and damage to property.
6. With seasonal humidity change you must inspect interior and exterior of furniture.
7. Single bed models are suitable for the weight of one person. Sleeping by more than one person will cause damage of the product.
8. Before any un-mounting or disassembly please contact Multimo for technical support and instruction. Failure to properly detach risks injury to person and damage to property.
9. For Bunk Beds:
 - a. Always use provided ladder when accessing top bunk.
 - b. Be slow, careful and aware of surroundings when opening top bunk.
 - c. Do not horseplay. Beds are to be slept on only.
 - d. Some have legs that fully extend when open- be aware of where the leg is and will be.



www.multimo.com